

greenworks **pro**[™]

2936007AU/2936107AU
/2933907AU

EN

CHARGER

OPERATOR MANUAL

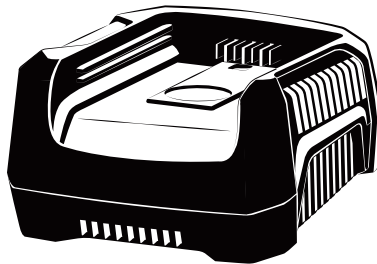
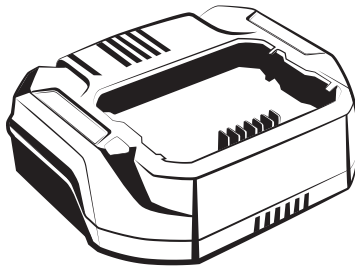

E8038

G60UC/CAC814

Greenworks Australia
A Division Jak Max P/L
380 Foley's Road Derrimut
Victoria, Australia 3026

www.greenworksaustralia.com

1	Important Safety Instructions.....	2	5	Maintenance.....	3
2	Symbols on the machine.....	2	5.1	Clean the machine.....	3
3	Recycle.....	2	5.2	Stow the machine.....	4
4	Operation.....	2	6	Troubleshooting.....	4
4.1	Charge procedure.....	2	7	Technical data.....	4
4.2	Examine the charger.....	3	8	Warranty.....	4
4.3	Mount the charger.....	3			

1 IMPORTANT SAFETY INSTRUCTIONS

- SAVE THESE INSTRUCTIONS - DANGER: TO REDUCE RISK OF FIRE OR ELECTRICAL SHOCK CAREFULLY OBEY THESE INSTRUCTIONS.
- Confirm the voltage available at each country location before using the charger.
- If the sharp of the plug does not fit the power outlet, use an attachment plug adaptor of the proper configuration for the power outlet.
- DO NOT probe the charger with conductive materials.
- DO NOT allow liquid inside the charger.
- DO NOT try to use the charger for any other purpose than what is presented in this manual.
- Unplug the charger before cleaning and when there is no battery pack in the charger.
- Do not try to connect two chargers together.
- Do not use the charger in the circumstances that the output Polarity does not match the load polarity.
- For indoor use only.
- The cover may under no circumstances be opened. If the cover is damaged, then the charger may no longer be used.
- Do not recharge non-rechargeable batteries.





▲ WARNING

To avoid risk of fire, electrical shock, or electrocution:

- Do not use a damp cloth or detergent on the battery or battery charger.
- Always remove the battery pack before cleaning, inspecting, or performing any maintenance on the tool.

2 SYMBOLS ON THE MACHINE

You can use below symbols on the machine. Please study them and learn their definitions. Correct interpretation of these symbols let you operate the tool better and safer.

Symbol	Explanation
	Class II
	For indoor use only
	Before charging, read the instructions
	Fuse

3 RECYCLE



Separate collection. You must not discard with usual household waste. If it is necessary to replace the machine, or if it is no more use to you, do not discard it with household waste. Make this machine available for separate collection.



Separate collection of used machine and packaging let you recycle materials and use them again. Use of the recycled materials helps prevent environmental pollution and decreases the requirements for raw materials.



At the end of their useful life, discard batteries with a precaution for our environment. The battery contains material that is dangerous to you and the environment. You must remove and discard these materials separately at a equipment that accepts lithium-ion batteries.

4 OPERATION

4.1 CHARGE PROCEDURE

i NOTE

Before use charge the battery pack fully to make sure that the battery pack can get the maximum run time. This battery pack does not have a memory. You can charge it all the time.

1. Connect the plug of charger (2) to an AC power outlet.
2. Put the battery pack (1) into the charger (2).

For charger: CAC805

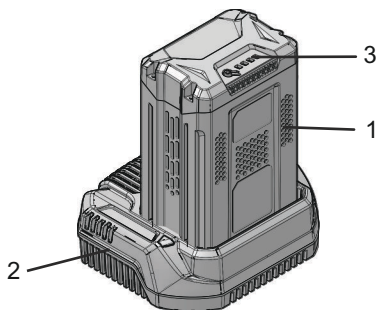

For charger: CAC814

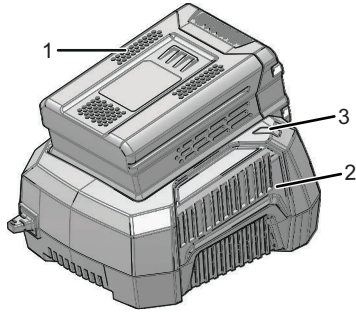

This is a diagnostic charger. The Charger LED Light (3) illuminates in a specified order to show the current battery status. They are as follows:

CHARGING PROCEDURE (LED INDICATOR)	
BATTERY IS CHARGING	⦿ GREEN BLINKING
FULLY CHARGED	● GREEN
BATTERY IS TOO WARM (RE-MOVE FOR APPROX. 30 MINUTES TO ALLOW TO COOL)	● RED
DEFECTIVE BATTERY (REMOVE AND REPLACE WITH A NEW BATTERY)	⦿ RED BLINKING

Incorrect Defect Note:

- Put the battery pack into the charger.
 - If the status LED blinks RED, remove the battery pack from the charger for 1 minute.
- Put the battery pack into the charger again.
 - If the status LED blinks GREEN, the battery pack is good.
 - If the status LED stays blinking RED, remove the battery pack and disconnect the charger.
- Wait for 1 minute and put the battery pack into the charger again.
 - If the status LED shows blinks GREEN, the battery pack is good.
 - If the status LED stays blinking RED, the battery pack is defective and it is necessary to replace the battery pack.

4.2 EXAMINE THE CHARGER

If the battery pack does not charge correctly:

- Examine the current of the power outlet with different machines. Make sure that the outlet works.
- Examine that the charger contacts are not short-circuited.

- If the charger is not under usual room temperature, move the charger and battery pack to a location where the temperature is between 6 °C and 40 °C .

▲ WARNING

If you put the battery pack into the charger in warm or hot environment, the charger LED light is red. Pull out the battery pack and let the battery cool for approximately 30 minutes.

4.3 MOUNT THE CHARGER

- Get the location of the wall to attach the charger.
- Use 2 wood screws to attach the charger on the wood studs.
- Drill two paralleled holes 4.5" (114 mm) on center.
- Use wall anchors and screws to attach the charger to the drywall.

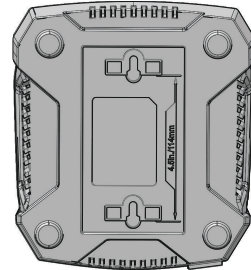

i NOTE

If you do not use the battery pack and charger for a long time, please remove the battery from the charger and pull out the AC power plug.

5 MAINTENANCE

5.1 CLEAN THE MACHINE

i NOTE

Keep the air vent free of blockage, saw dust, and wood dust. Do not spray, wash, or put the air flow in water.

- Clear the unwanted material out of the air vent with a vacuum.
- Clean housing and the plastic components with a dry and soft cloth.

i IMPORTANT

Do not use strong solvents or detergents on the plastic housing or components.

5.2 STOW THE MACHINE

- Remove the battery pack before you store the charger or disconnect the charger.

6 TROUBLESHOOTING

PROBLEM	POSSIBLE CAUSE	SOLUTION
Charger doesn't work. Charger shows defective mode. (LED flashes Red)	Battery pack or charger is defective or there is a bad connection between the battery pack and charger.	Try to remove and reinsert the battery pack in the charger.
		Try charging a different battery pack.
		Unplug the charger and wait until the red LED goes out, then reconnect the plug to the power supply.
Charger doesn't work. Charger shows evaluation mode (LED indicates Red solid ON).	Battery pack is either too hot, or too cold.	Allow the battery pack to reach normal temperature. Charging will begin when the battery pack returns to 3°C-47°C (37°F-117°F).

the owner's manual might be rejected for warranty. Normal wear, and wear parts are not considered as warranty. The original manufacturer warranty is not affected by any additional warranty offered by a dealer or retailer.

A faulty product must be returned to the point of purchase in order to claim for warranty, together with the proof of purchase (receipt).

7 TECHNICAL DATA

Model	CAC805
Voltage	60 V
Input	230V AC 50/60Hz, 2A Max
Output	60V DC 2A

Model	CAC814
Voltage	60 V
Input	230V AC 50/60Hz, 6A Max
Output	60V DC 6A

8 WARRANTY

(The full warranty terms and conditions can be found on webpage)

The warranty is 4 years on the product, and 2 years on batteries (consumer/private usage) from the date of purchase. This warranty covers manufacturing faults. A faulty product under warranty might be either repaired or replaced. A unit that has been misused or used in other ways than described in