

greenworks[®]

COMMERCIAL

7405207AU
OZ972R

EN ZERO-TURN MOWER

OPERATOR MANUAL

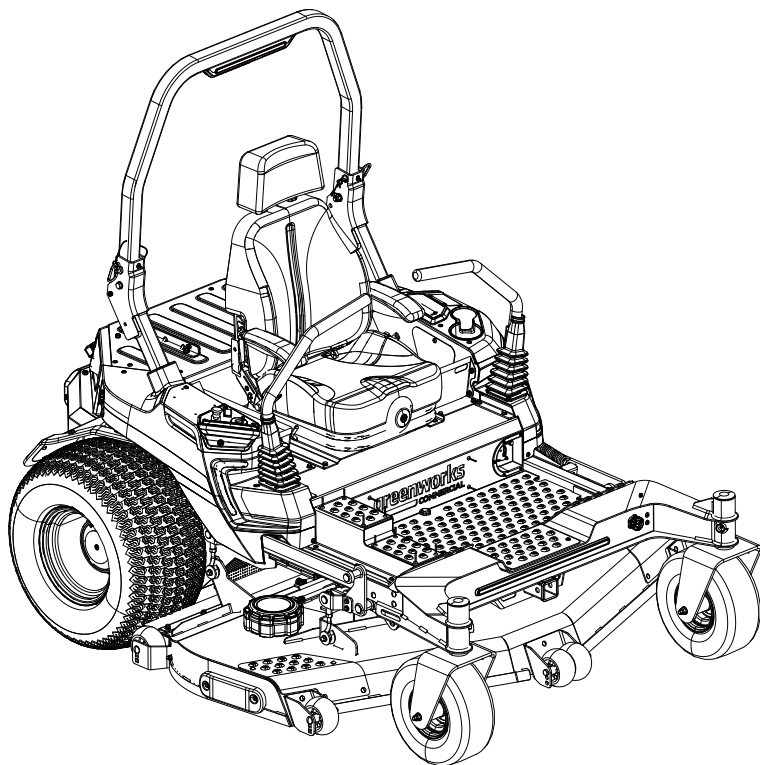

E8038

Greenworks Australia
A Division Jak Max P/L
380 Foley's Road Derrimut
Victoria, Australia 3026

www.greenworksaustralia.com

ZTB90020

1	Introduction.....	2	7.3	Move the mower manually.....	24
1.1	Product description.....	2	8	Clean and storage.....	25
1.2	Intended use.....	2	8.1	Clean the product.....	25
1.3	Symbols on the product.....	2	8.2	Store the product.....	25
2	Safety.....	2	9	Maintenance.....	25
2.1	Safety definitions.....	2	9.1	Maintenance safety.....	25
2.2	General safety warnings.....	3	9.2	Battery maintenance.....	25
2.3	Ride-on mower safety warnings.....	4	9.3	Charge the product.....	26
2.4	Safe practices for ride-on mowers.....	5	9.4	Recommended maintenance schedules.....	27
3	Assembly.....	8	9.5	Lubrication.....	27
3.1	Install the seat.....	8	9.6	Check tire pressure.....	27
3.2	Install the steering control lever.....	9	9.7	Torque values.....	28
4	Features and controls.....	10	9.8	Service the mower blades.....	28
4.1	Product controls.....	10	10	Troubleshooting.....	31
5	Electrical system.....	13	11	Technical data.....	33
5.1	Electrical system safety.....	13	12	Warranty.....	33
5.2	Electrical system information.....	14	13	Errors.....	33
6	Operation.....	14	13.1	Display screen error code.....	34
6.1	Start the product.....	14	13.2	BMS error code.....	35
6.2	Cutting height adjustment.....	14	13.3	Battery charger error code.....	39
6.3	Stop the product.....	15	13.4	Right wheel motor controller error code.....	41
6.4	Digital display.....	15	13.5	Left wheel motor controller error code... 46	
6.5	App operation tips.....	21	13.6	Left blade motor controller error code... 50	
6.6	Zero-turn mower driving practice.....	21	13.7	Middle blade motor controller error code.....	52
6.7	Mowing.....	22	13.8	Right blade motor controller error code.....	54
6.8	Mowing patterns.....	23	13.9	Deck linear actuator error code.....	55
6.9	Mowing recommendations.....	23			
7	Transportation.....	24			
7.1	Transport the mower.....	24			
7.2	Neutral bypass lever.....	24			

1 INTRODUCTION

1.1 PRODUCT DESCRIPTION

This product is a battery-operated zero-turn mower with electric motors.













We are committed to continuously improving our products and reserve the right to modify the design and appearance without prior notice.









1.2 INTENDED USE

The product is designed for efficiently cutting and maintaining grass on residential lawns and outdoor spaces. It is not designed for any other purpose.

1.3 SYMBOLS ON THE PRODUCT

Read the safety decals before operating your product. The warnings have been developed for your safety. Understand and follow all safety decals to reduce the risk of a personal injury or property damage.

Symbol	Explanation
	Protection from splashing water.
	Voltage
	Kilogram
	Pound
	Indicates a potential personal injury hazard.
	To reduce the risk of injury, user must read and understand operator's manual before using this product.
	Wear ear protection.
	Always wear safety goggles or safety glasses with side shields and a full face shield when operating this product.
	Professional training is required before operating the product.
	Do not open or remove safety shields while the product is running.
 	To reduce the risk of injury, keep hands and feet away from rotating parts. Do not operate unless discharge cover or grass bag is in its proper place. If damaged, replace immediately.
	Do not tow this product, it may cause damage to the drive system.

Symbol	Explanation
	Never carry children or anyone, even when the blades are off.
	Always look down and behind you when maneuvering in reverse or turning around. Make sure children, bystanders, and pets are clear of the area.
	Use extra caution on slopes. Do not mow slopes greater than 15 degrees. Do not use on slopes near open water.
	Remove objects that can be thrown by the blade in any direction. Wear safety glasses.
	Keep all bystanders at least 30m (100ft.) away.
	Do not step.
	Pull the neutral bypass lever outward to release the drive brake. Never unlock the neutral bypass lever on slopes. It can cause a loss of control.
	CAUTION — Do not stare at operating lamp.
	Disconnect power before maintenance.

2 SAFETY

2.1 SAFETY DEFINITIONS

Warnings, cautions, and notes are used to point out especially important parts of the manual.

▲ WARNING

THERE IS A RISK OF INJURY OR DEATH FOR THE OPERATOR OR BYSTANDERS, IF THE INSTRUCTIONS IN THE MANUAL ARE NOT OBEYED.

▲ CAUTION

THERE IS A RISK OF DAMAGE TO THE PRODUCT, OTHER MATERIALS, OR THE ADJACENT AREA, IF THE INSTRUCTIONS IN THE MANUAL ARE NOT OBEYED.

Note: Used to give more information that is necessary in a given situation.

2.2 GENERAL SAFETY WARNINGS

▲ WARNING

Read all safety warnings, instructions, illustrations and specifications provided with this product.

Failure to follow all instructions listed below may result in electric shock, fire and/or serious injury.

Save all warnings and instructions for future reference.

The term "product" in the warnings refers to your mains-operated (corded) product or BATTERY-operated (cordless) product.

2.2.1 WORK AREA SAFETY

- **Keep work area clean and well lit.** *Cluttered or dark areas invite accidents.*
- **Do not operate the product in explosive atmospheres, such as in the presence of flammable liquids, gases or dust.** *The product creates sparks which may ignite the dust or fumes.*
- **Keep children and bystanders away while operating the product.** *Distractions can cause you to lose control.*

2.2.2 ELECTRICAL SAFETY

- **Product plugs must match the outlet. Never modify the plug in any way. Do not use any adapter plugs with earthed (grounded) product.** *Unmodified plugs and matching outlets will reduce risk of electric shock.*
- **Avoid body contact with earthed or grounded surfaces, such as pipes, radiators, ranges and refrigerators.** *There is an increased risk of electric shock if your body is earthed or grounded.*
- **Do not expose the product to rain or wet conditions.** *Water entering a product will increase the risk of electric shock.*
- **Do not abuse the cord. Never use the cord for carrying, pulling or unplugging the product. Keep cord away from heat, oil, sharp edges or moving parts.** *Damaged or entangled cords increase the risk of electric shock.*
- **When operating the product outdoors, use an extension cord suitable for outdoor use.** *Use of a cord suitable for outdoor use reduces the risk of electric shock.*
- **If operating the product in a damp location is unavoidable, use a Residual Current Device (RCD) protected supply.** *Use of an RCD reduces the risk of electric shock.*
- **Do not clean the product with water from a hose or a pressure washer.** *Water entering a product will increase the risk of electric shock.*

- **Do not operate the product in rain.** *Water entering a product will increase the risk of electric shock.*

2.2.3 PERSONAL SAFETY

- **Stay alert, watch what you are doing and use common sense when operating the product. Do not use the product while you are tired or under the influence of drugs, alcohol or medication.** *A moment of inattention while operating the product may result in serious personal injury.*
- **Use personal protective equipment. Always wear eye protection.** *Protective equipment such as a dust mask, non-skid safety shoes, hard hat, or hearing protection used for appropriate conditions will reduce personal injuries.*
- **Prevent unintentional starting. Ensure the switch is in the off-position before connecting to power source and/or Battery pack, picking up or carrying the product.** *Carrying power tools with your finger on the switch or energizing power tools that have the switch on invites accidents.*
- **Remove any adjusting key or wrench before turning the product on.** *A wrench or a key left attached to a rotating part of the product may result in personal injury.*
- **Do not overreach. Keep proper footing and balance at all times.** *This enables better control of the product in unexpected situations.*
- **Dress properly. Do not wear loose clothing or jewelry. Keep your hair, clothing away from moving parts.** *Loose clothes, jewelry or long hair can be caught in moving parts.*
- **If devices are provided for the connection of dust extraction and collection facilities, ensure these are connected and properly used.** *Use of dust collection can reduce dust-related hazards.*
- **Do not let familiarity gained from frequent use of tools allow you to become complacent and ignore tool safety principles.** *A careless action can cause severe injury within a fraction of a second.*

2.2.4 PRODUCT USE AND CARE

- **Do not force the product. Use the correct product for your application.** *The correct product will do the job better and safer at the rate for which it was designed.*
- **Do not use the product if the switch does not turn it on and off.** *Any product that cannot be controlled with the switch is dangerous and must be repaired.*
- **Disconnect the plug from the power source and/or remove the BATTERY pack, if detachable, from the product before making any adjustments, changing accessories, or storing the product.** *Such preventive safety measures reduce the risk of starting the product accidentally.*

- **Store an idle product out of the reach of children and do not allow persons unfamiliar with the product or these instructions to operate the product.** *A product is dangerous in the hands of untrained users.*
- **Maintain the product and accessories. Check for misalignment or binding of moving parts, breakage of parts and any other condition that may affect the operation of the product. If damaged, have the product repaired before use.** *Many accidents are caused by poorly maintained product.*
- **Keep cutting tools sharp and clean.** *Properly maintained cutting tools with sharp cutting edges are less likely to bind and are easier to control.*
- **Use the product, accessories and tool bits etc. in accordance with these instructions, taking into account the working conditions and the work to be performed.** *Use of the product for operations different from those intended could result in a hazardous situation.*
- **Keep handles and grasping surfaces dry, clean and free from oil and grease.** *Slippery handles and grasping surfaces do not allow for safe handling and control of the product in unexpected situations.*
- **Remove the key or disable the product when leaving the product unattended.** *The product is dangerous to untrained users.*

2.2.5 BATTERY TOOL USE AND CARE

- **Recharge only with the charger specified by the manufacturer.** *A charger that is suitable for one type of battery pack may create a risk of fire when used with another battery pack.*
- **Use the product only with specifically designated battery packs.** *Use of any other battery packs may create a risk of injury and fire.*
- **When battery pack is not in use, keep it away from other metal objects, like paper clips, coins, keys, nails, screws or other small metal objects, that can make a connection from one terminal to another.** *Shorting the battery terminals together may cause burns or fire.*
- **Under abusive conditions, liquid may be ejected from the battery; avoid contact.** *If contact accidentally occurs, flush with water. If liquid contacts eyes, additionally seek medical help. Liquid ejected from the battery may cause irritation or burns.*
- **Do not use a battery pack or product that is damaged or modified.** *Damaged or modified batteries may exhibit unpredictable behavior resulting in fire, explosion or risk of injury.*
- **Do not expose a battery pack or product to fire or excessive temperature.** *Exposure to fire or temperature above 130°C may cause explosion.*
- **Follow all charging instructions and do not charge the battery pack or product outside the**

temperature range specified in the instructions. *Charging improperly or at temperatures outside the specified range may damage the battery and increase the risk of fire.*

2.2.6 SERVICE

- **Have your product serviced by a qualified repair person using only identical replacement parts.** *This will ensure that the safety of the product is maintained.*
- **Never service damaged battery packs.** *Service of battery packs should only be performed by the manufacturer or authorized service providers.*

2.3 RIDE-ON MOWER SAFETY WARNINGS

- **Do not use the mower in bad weather conditions, especially when there is a risk of lightning.** *This decreases the risk of being struck by lightning.*
- **Thoroughly inspect the area for wildlife where the mower is to be used.** *Wildlife may be injured by the mower during operation.*
- **Thoroughly inspect the area where the mower is to be used and remove all stones, sticks, wires, bones, and other foreign objects.** *Thrown objects can cause personal injury.*
- **Before using the mower, always visually inspect to see that the blade and the blade assembly are not worn or damaged.** *Worn or damaged parts increase the risk of injury.*
- **Keep guards in place.** *Guards must be in working order and be properly mounted. A guard that is loose, damaged, or is not functioning correctly may result in personal injury.*
- **Keep all cooling air inlets clear of debris.** *Blocked air inlets and debris may result in overheating or risk of fire.*
- **While operating the mower, always wear non-slip and protective footwear.** *Do not operate the mower when barefoot or wearing open sandals. This reduces the chance of injury to the feet from contact with the moving blade.*
- **While operating the mower, always wear long pants.** *Exposed skin increases the likelihood of injury from thrown objects.*
- **Do not operate the mower on slopes greater than 15 degrees.** *This reduces the risk of loss of control, slipping and falling which may result in personal injury.*
- **When working on slopes, always be sure of your footing.** *This reduces the risk of loss of control, slipping and falling which may result in personal injury.*
- **Do not mow from side-to-side when operating mowers on unlevel or sloped ground.** *Always mow slopes in the up-and-down direction. This*

reduces the risk of loss of control, slipping and falling which may result in personal injury.

- **Do not touch blades and other hazardous moving parts while they are still in motion.** This reduces the risk of injury from moving parts.
- **When clearing jammed material or cleaning the mower, make sure all power switches are off and remove (or activate) the disabling device.** Unexpected operation of the mower may result in serious personal injury.
- Use extreme caution when reversing or pulling the lawnmower towards you. Always be aware of your surroundings.
- The user and technician **SHALL** carefully review **ALL** applicable original equipment manufacturer (OEM) safety-related repair manual procedures, training, and precautions before use, maintenance and service.

Note: The user and technician should consult a medical professional if they have or are wearing:

- An implanted defibrillator.
- A cardiac pacemaker.
- An internal analgesic medication pump.
- An insulin pump.
- Hearing aids.
- Other medical devices.

2.4 SAFE PRACTICES FOR RIDE-ON MOWERS

▲ WARNING

This mower is capable of amputating hands and feet and throwing objects at high speed. Failure to read and follow the warnings and safety instruction in this manual could result in severe personal injury or death to the operator or bystanders.

2.4.1 GENERAL SAFETY

- Do not use battery-operated ride-on mower in rain.
- Only allow responsible, capable adults who are familiar with the instructions to operate this product.
- Safe operation requires your full attention and capabilities.
- Always look where you are going and be aware of your surroundings.
- Listen to the product and be aware of any change.
- Feel the product and its responses from both your inputs and the environment.
- Remain focused on your task.
- Always wear proper eye protection that complies with the latest safety standards in order to reduce the risk of eye injury while operating or performing any adjustment or repair. See ANSI Z87.1.
- Do not operate product unless discharge guard or other safety devices are in place and working.

- Always wear a face mask or a dust mask while operating the mower in a dusty environment.
- Always dress properly. The wearing of protective gloves and safety footwear is recommended.
- Never operate the product while using a mobile phone or any other electronic device. Operating while distracted can increase the risk of serious personal injury to the operator and bystanders.
- Do not operate the equipment while wearing sandals, tennis shoes, sneakers, shorts or any type of loose-fitting clothing. Wear safety shoes, hard hats, long pants, protective eyewear and hearing protection during operation to reduce the risk of personal injury. Avoid loose-fitting clothing, jewelry and any other apparel that could be caught on moving parts. Secure hair above shoulder level before starting work.
- Never carry passengers and keep bystanders away.
- Follow the manufacturer's recommendation for wheel weights or counterweights.

2.4.2 PREPARATION BEFORE OPERATING

- Clear the operating area of any objects which could be thrown by or interfere with operation of the product.
- Keep the area of operation clear of all bystanders, particularly small children. Stop the product and attachment(s) if anyone enters the area.
- Do not operate the product without the entire grass catcher, discharge chute, or other safety devices in place and functioning properly. Check frequently for signs of wear or deterioration and replace as needed.
- Wear appropriate personal protective equipment such as safety glasses, hearing protection, and footwear.
- Do not carry passengers anywhere on the product. Keep pets and bystanders out of the mowing area during operation.

2.4.3 OPERATING

- Always drive with both hands. Do not drive with just one hand.
- Only operate the product in daylight or good artificial light.
- Avoid holes, ruts, bumps, rocks, or other hidden hazards. Uneven terrain could overturn the product or cause operator to lose their balance or footing.
- Do not put hands or feet near rotating parts or under the product. Keep clear of the discharge opening at all times.
- Do not direct discharge material toward anyone. Avoid discharging material against a wall or obstruction. Material may ricochet back toward the operator. Stop the blade(s) when crossing gravel surfaces.

- Never leave an activated product unattended. Take appropriate precautions when stopping the product or leaving the operator's position. Always stop on level ground. Disengage the PTO, set the parking brake, switch off the power and remove the key before standing up from the operator's position.
- Do not mow in reverse unless absolutely necessary. Always look down, behind and to the side before changing directions or backing up.

2.4.4 CHILDREN SPECIFIC

- Tragic accidents can occur if the operator is not alert to the presence of children. Children are often attracted to the product and the mowing activity. Never assume that children will remain where you last saw them.
- Keep children out of the operating area and under the watchful care of another responsible adult other than the operator.
- Do not carry children, even with the blade(s) off. Children could fall off and be seriously injured or interfere with safe operation. Children who have been given rides in the past could suddenly appear in the mowing area for another ride and be run over or backed over by the product.

2.4.5 USE A RAMP

- When loading or unloading the product from a trailer, always use full width ramps that extend beyond the width of the product.
- This provides a surface for the mower frame to contact if the unit starts to tip backwards. It also reduces the risk of a wheel going off and the product tipping over.
- Do not exceed a 15-degree angle between the ramp and the ground or between the ramp and the trailer or truck.
- Become familiar with the mower's controls and confident in its smooth operation before attempting to drive it up or down a ramp.
- Use slow drive mode and drive carefully.
- Avoid any sudden movement of the controls and use only slow, even acceleration.

2.4.6 TOWING

- Tow only with a product that has a hitch designed for towing. Do not attach towed equipment except at the hitch point.
- Follow the manufacturer's recommendation for weight limits for towed equipment and towing on slopes. See **Rear Trailer Hitch** section. (Reference 4.1.8)
- Never allow children or others in or on towed equipment.
- On slopes, the weight of the towed equipment may cause loss of traction and loss of control.
- Travel slowly and allow extra distance to stop.

2.4.7 SERVICE

- Keep product in good working order. Replace worn or damaged parts.
- Use caution when servicing blades. Wrap the blade(s) or wear gloves. Replace damaged blades. Do not repair or alter blade(s).
- Do not charge ride-on mower in rain, or wet locations.
- Store idle ride-on mower indoors - When not in use, ride-on mower should be stored in an indoor dry and locked-up place - out of reach of children.
- Turn off and remove start key before servicing, cleaning, or removing material from the ride-on mower.

Save all warnings and instructions for future reference.

2.4.8 SLOPE OPERATION

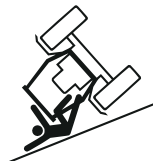

Slopes are a major factor related to accidents. Operation on slopes requires extra caution. To reduce the risk of injury, never operate the product under any condition where you experience wheel slipping or sliding, or where wheel traction or mower stability and control are in doubt. The product may slide even if the wheels are stopped. These conditions increase the risk of roll over.

- Never operate on a slope greater than 15 degrees - a slope that has 1.6 metres of elevation change over any 6 metres segment. See **Slope Identification Guide** (Reference 2.4.9) in this Operator Manual.
- Always mow slopes in the up and down direction, never side to side.
- Reduce speed and use extra care when mowing on slopes. If you cannot back up the slope or if you feel uncomfortable, do not drive on the slope.
- Avoid turning the product down slopes. Turn up slopes.
- Always keep the product in gear when going down slopes. Do not coast downhill.
- Avoid starting and stopping on slopes. Avoid making sudden changes in speed or direction. Make turns slowly and gradually.
- Avoid mowing grass that is slippery, wet, or soft. Operating on wet or soft slopes can cause loss of control, which can lead to tip over.
- Use extra care while operating the product with a grass catcher or other attachments. They can affect the stability of the product.

2.4.9 SLOPE IDENTIFICATION GUIDE

▲ WARNING

To reduce the risk of serious personal injury or death, never operate on slopes greater than 15 degrees. Always check the degree of slope on the lawn surface before attempting to mow in that area.

- Download an inclinometer app onto your mobile device that measures slopes.
- Place a flat piece of wood or metal, 122-183 cm in length, on the surface of the slope.
- Open the app and place your phone (2) on the flat piece of metal or wood (1) to determine the exact slope of your lawn. Do not mow if the slope is greater than 15 degrees.

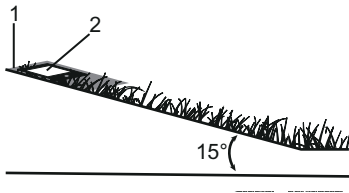

2.4.10 ROLL OVER PROTECTION SYSTEM (ROPS)

The Roll Over Protection System (ROPS) is an important and effective safety device. Do not remove, repair or alter the ROPS. Replace a damaged component of the ROPS.

▲ WARNING

Keep the roll bar in the raised and locked position and fasten the seat belt around your waist when operating the product. There is no roll over protection when the roll bar is down. When the roll bar is raised and your seat belt is fastened, do not jump off the mower if it tips. It is safer to be secured by the seat belt with the roll bar raised.

The roll bar is designed to fold down to allow the operator to drive under overhanging obstacles and fit the mower into trailers. Lower the roll bar only when absolutely necessary. Never use the seat belt when the roll bar is down. Raise the roll bar as soon as overhead clearance permits. Never remove the roll bar.

▲ WARNING

In order to avoid serious injury or death from roll over, follow the warnings listed below.

- Always fasten the seat belt when the roll bar is in the raised position.
- Never use the seat belt when the roll bar is down.

- Keep the roll bar raised and locked unless absolutely necessary to pass under an obstacle. There is no roll over protection when the roll bar is down.
- Overhanging obstacles can be dangerous. Before passing under tree branches and other obstacles, always ensure sufficient clearance. If absolutely necessary, lower the roll bar to pass under the object. Return the roll bar to the raised and locked position immediately after clearing the obstacle.
- Never modify, alter or remove the roll bar.
- The roll bar has a maximum weight limit. Never exceed the weight rating marked on the roll bar.
- Read and follow the instructions about inspecting and maintaining the ROPS.

Inspect the Roll Bar

▲ WARNING

Failure to properly inspect and maintain the roll bar can result in serious injury or death.

Inspect the roll bar to ensure that it has not been damaged, weakened or otherwise compromised during use. Inspect for evidence of misuse, wear, modification, or damage. Contact your authorized servicing dealer if you have any questions about the condition of the roll bar.

- Do not attempt to repair a roll bar. It must be inspected and replaced by the manufacturer following a collision, rollover, or other overhead impact to ensure there is no microstructural damage, which could reduce its effectiveness. Avoid welding, straightening segments, or attempting repairs on the roll bar. Likewise, refrain from drilling holes or welding anything to it, as this will compromise its structural integrity.
- Before using the mower for the first time:
 1. Make sure the mower's gross weight, including attachments, payload, and operator, is below the maximum weight stated on the roll bar label.
 2. Check for missing, damaged, or loose hardware. Make sure all of the components are in place and securely attached.
 3. Check for proper installation of the components of the roll bar. If you have questions, consult your authorized servicing dealer.
- **Before each use or daily**—Inspect the roll bar and mounting hardware for:
 1. Deformation or twisting of the roll bar.
 2. Missing or damaged hardware—including hardware that cannot be re-tightened.
 3. Cracks in the metal tubing or welds.
 4. Corrosion on the roll bar or the ROPS hardware.
 5. Unauthorized welds, holes, or hardware.

- In addition, confirm that the roll bar label and ROPS warning information is still in place and readable.

Inspect the Seat Belt

▲ WARNING

The seat belt is another component of the roll over protection system. Inspect the seat belt regularly to ensure that it can perform its intended safety function.

- Before each use, check for wear or damage caused by normal degradation, misuse, modification, or abuse.
 - Check for fraying, cuts, or other wear in the fabric of the seat belt.
 - Check the seat belt for dirt and debris. Remove dirt. Confirm proper mechanical operation by testing extension and retraction of the belt and the mechanism securing the buckle and latch. If the polymer or metal parts are damaged or cracked, or if latching and releasing the buckle are difficult, or if the seat belt has any other mechanical problems, have the seat belt replaced by your authorized servicing dealer.

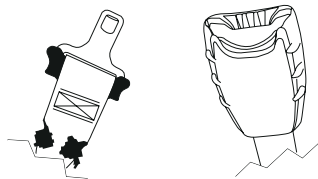

2.4.11 DROP-OFFS AND WATER

▲ WARNING

Drop-offs around steps and water are a common hazard. Never operate your mower down a slope towards water, a retaining wall, or other drop-off. Use extra caution when operating the mower in the vicinity of such hazards.

▲ WARNING

To reduce the risk of falling into water, down steps, or over the edge of a drop-off, always leave yourself two mower widths of clearance between your mower and the hazard. Failure to maintain sufficient clearance may result in serious injury, death, or drowning.

2.4.12 SAFETY START INTERLOCK SYSTEM

This mower is equipped with a safety start interlock system consisting of the parking brake, operator presence control switch, PTO switch and start key to protect the operator and others from accidental injury due to unintentional drive activation.

Check mower safety start interlock system daily prior to operation. This system is an important mower safety feature. It should be repaired immediately if it malfunctions. The mower incorporates a separate operator presence control switch which will stop the drive system and blade motors when the operator is not in place for any reason while the mower is operating. This is a safety feature designed to prevent runaway or accidental entanglement.

▲ WARNING

The safety interlock system must not be disconnected or bypassed. Doing so could cause the product to operate unexpectedly, resulting in personal injury.

To inspect the system:

- The operator must be on the seat when testing the operator presence control switch.
- Insert the start key and turn to ON position.
- Make sure the steering control levers are pivoted outwards to engage the parking brake.
- Pull the PTO switch to engage the blade motor.
- Slowly stand up from the seat. The mower blades should stop in 3 seconds.
- If the mower blades fail to stop when the operator is not in place, contact your authorized servicing dealer immediately. Do not operate the mower until the safety start interlock system has been repaired.

3 ASSEMBLY

This section describes how to assemble and adjust the product.

▲ WARNING

CAREFULLY READ AND UNDERSTAND THE SAFETY CHAPTER AND THE ASSEMBLY INSTRUCTIONS BEFORE YOU ASSEMBLE THE PRODUCT.

3.1 INSTALL THE SEAT

- Position the seat over the seat panel and align holes.
- Install the washers and nuts under the seat panel and tighten securely with a 13 mm socket applying torque within the range of 9 - 10 N·m.

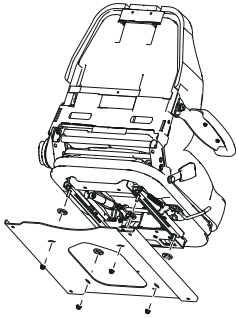

3. Connect the wire connector to the seat plug located behind the seat. Ensure the plugs are securely attached.

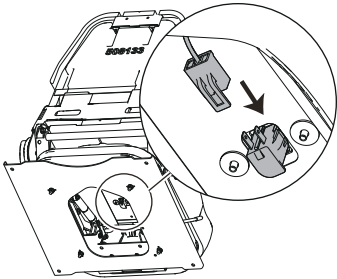

4. Position the seat assembly on the battery compartment and install the four M8x20 hexagon bolts and tighten them with a 13 mm socket applying torque within the range of 8 - 10 N·m.

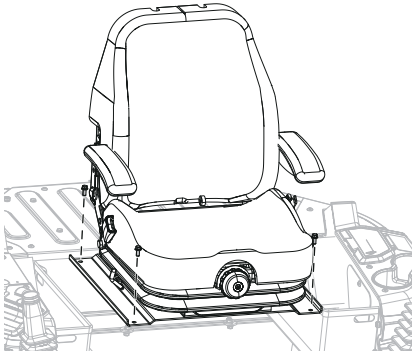

5. Insert the headrest into the two holes on the backrest by pressing the side button.

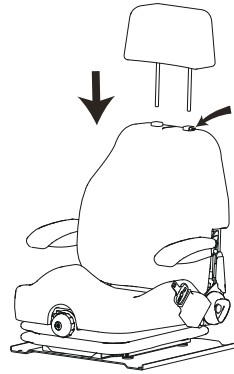

3.2 INSTALL THE STEERING CONTROL LEVER

The two steering control levers control the mower's speed, direction, stopping, neutral lock, and parking brake, serving to steer, adjust speed, reduce speed, stop, and change direction.

▲ WARNING

The left and right steering levers should be adjusted so that they align and mirror each other when in the neutral position. NEVER install the steering levers in an asymmetrical operating height.

1. Lift the steering control lever to align the holes in the lever with the holes in the mounting pole.
2. Select the preferred steering-lever operating height. Insert the bolt together with the washer into the hole. Secure the screw as close to the center of the hole as possible to ensure proper alignment.

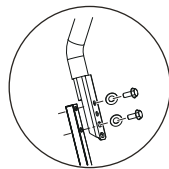

Position 1

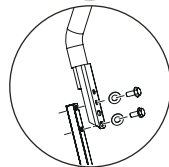

Position 2

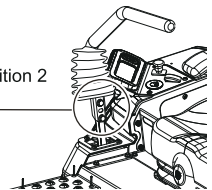

3. Use a 16 mm wrench to tighten the steering control lever bolts, applying torque within the range of 20 - 30 N·m.

4. Fasten the rubber cover of each lever by tightening three screws with a T30 wrench and applying torque within the range of 5 - 8 N.m.

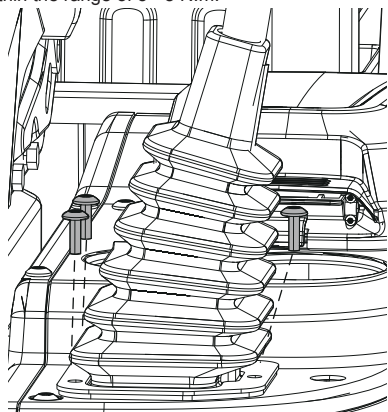

5. After installing both rubber covers, ensure that both handles mirror each other and automatically align after being pulled backwards.

▲ CAUTION

Do not install the steering control levers in reverse.

Note: Always drive with both hands on the steering control levers. Do not drive with just one hand.

4 FEATURES AND CONTROLS

The following section provides a brief description of the function of individual controls. For information on starting, stopping, driving, and mowing, refer to the **Operation** (Reference 6) section.

4.1 PRODUCT CONTROLS

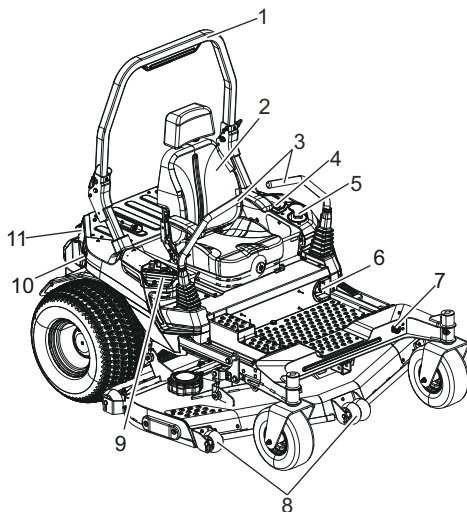

- | | |
|---------------------------|---------------------|
| 1 Roll bar | 7 Front ETO socket |
| 2 Suspension seat | 8 Anti-scalp wheels |
| 3 Steering control levers | 9 Control panel |
| 4 USB Charging port | 10 Rear ETO socket |
| 5 Cup holder | 11 Charging port |
| 6 Service switch | |

4.1.1 RAISE AND LOWER THE ROLL BAR

▲ WARNING

Avoid serious injury or death from roll over:

- Wear seat belt when the roll bar is raised.
- There is no rollover protection when the roll bar is lowered.
- Lower the roll bar only when necessary and NEVER remove it.
- Do NOT use seat belt with the roll bar down.
- Raise the roll bar when space allows.
- Do NOT jump off if the mower tips.

To lower the roll bar:

1. Extract R pins from clevis pins.
2. Remove clevis pins. Adjust the top bar if needed to free the pins from the roll bar.

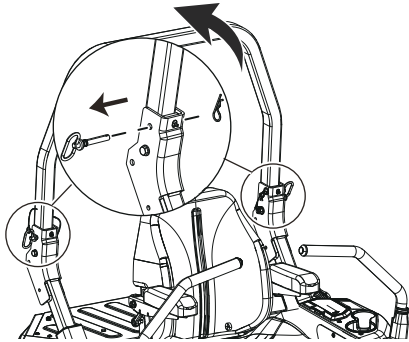

3. Lower the roll bar.
4. Install the clevis pins and R pins to secure the roll bar down.

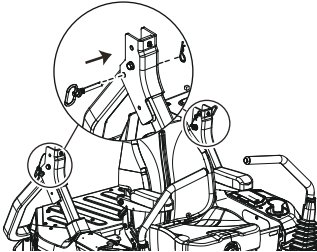

To raise the roll bar:

1. Raise the top roll bar into the raised position.
2. Insert the clevis pins through the roll bar.
3. Then install the R pins into the clevis pins.

4.1.2 SUSPENSION SEAT

The mower is equipped with a suspension seat. This seat has several additional options. See the figure and list below for the location of the seat's features and brief description of their function.

1. **Retractable Seat Belt:** The seat belt is used to secure the operator in the seat.

Note: The seat belt should always be worn when the roll bar is in the raised position. The seat belt should never be worn when the roll bar is in the down position.

2. **Suspension Adjustment Knob:** The suspension adjustment knob adjusts the suspension of the seat. Turn the adjustment knob until the display scale has a reading that matches the weight of the operator.
3. **Seat Adjustment Lever (Forwards / Backwards):** The seat can be adjusted forward and back. Lift the seat adjustment lever and hold, position the seat as desired, and release the lever to lock the seat in position.
4. **Angle Adjustment Knob:** Rotate the knob to adjust the angle of the seat as desired.

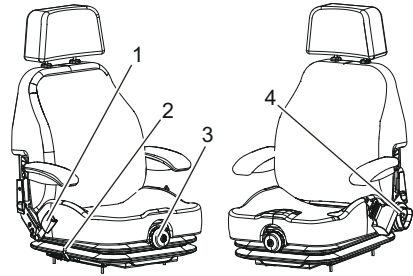

▲ WARNING

Be sure the seat is locked before operating the mower. A seat that is not secure can cause the operator to shift and lose control of the mower and result in possible death or serious personal injury.

4.1.3 STEERING CONTROL LEVER

The steering control levers control the direction of the mower.

FRONT OF MOWER FACES THIS DIRECTION

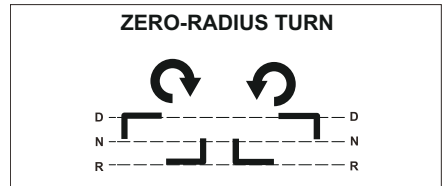
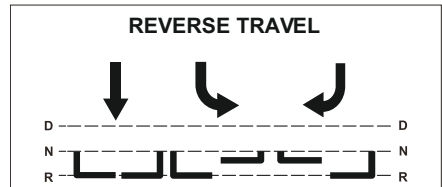
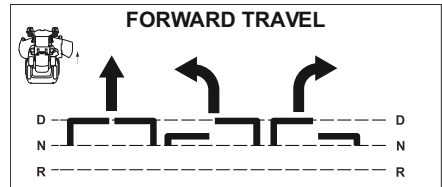

N= NEUTRAL POSITION

D= DRIVE POSITION

R= REVERSE POSITION

Direction of arrows indicate direction of mower movement

 Left steering control lever

 Right steering control lever

The left steering control lever controls the left rear drive wheel and the right steering control lever controls the right rear drive wheel.

Tilting both steering control levers outwards from the NEUTRAL position will engage the parking brake.

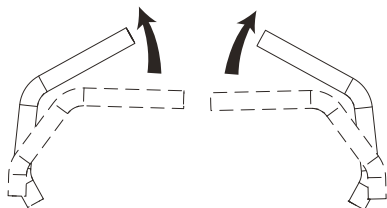

Tilting steering control levers in towards the NEUTRAL position will disengage the parking brake.

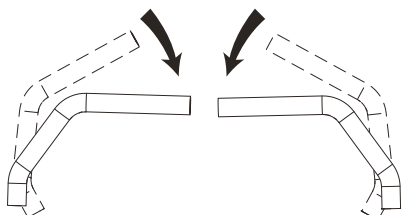

Note: The further a steering control lever is moved away from the neutral position, the faster the drive wheel will turn.

See the **Zero-turn Mower Driving Practice** section (Reference 6.6) for steering instructions.

4.1.4 SERVICE SWITCH

The service switch is only used for maintenance. Keep the switch in the ON position during normal operation. Before attempting any maintenance, stop the mower completely and then turn the service switch to the OFF position. Once maintenance is complete, return switch to the ON position.

4.1.5 ELECTRIC TAKE OFF (ETO) SOCKET

The mower can be used with other attachments designed specifically for this unit, such as an accessory blower. The attachments can be powered by the mower with the ETO socket (1) in the front part of the mower and mounted to the front hitch (2) if the attachment has the matched port. Another ETO socket (3) is located at the rear part of the mower.

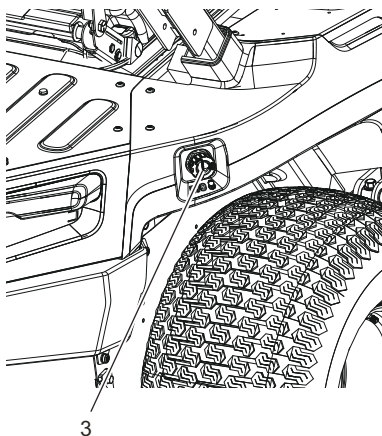
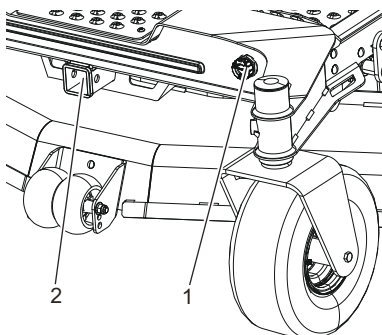

4.1.6 ANTI-SCALP WHEELS

These anti-scalp wheels are designed to minimize scalping when mowing on rough, uneven terrain. After setting the cutting height, adjust the anti-scalp wheels (2) so they extend below the deck but do not contact the ground. They should always be at least 0.6-1.9 mm below the deck (1). With the mower sitting on a flat level surface, the wheel position can be adjusted up or down as needed from 1.9-5.7 mm from the anti-scalp wheels (2) to the ground.

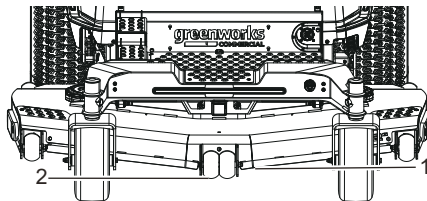

Move the wheels up or down - using the different axle mount holes in the wheel mount bracket (if applicable on model).

1. After adjusting the cutting height, adjust the anti-scalp wheels by removing the locking flange nut, the hex bolt which fix the wheels.
2. Select a hole so that the wheel is positioned to the corresponding height-of-cut desired.

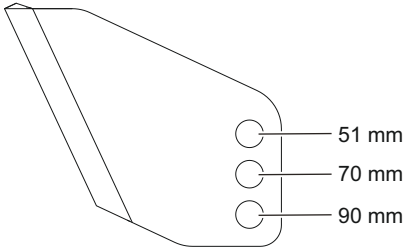

Note: For cutting height over 90 mm use the bottom hole. The anti-scalp wheels will be effective against scalping.

3. Install the locking flange nut and the hex nut.
4. Repeat the adjustment on the other anti-scalp wheels.

4.1.7 CONTROL PANEL

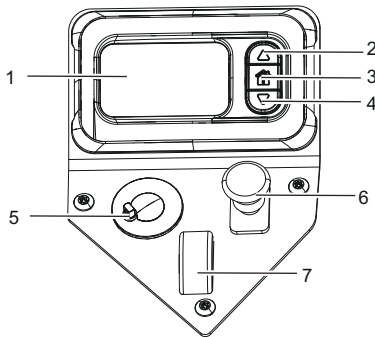

#	Name	Function
1	Digital display	This display shows important electrical system information. Refer to the Electrical section for complete information.
2	Switch page - UP	Switching between pages, direction up.
3	Home/back button	Return to prior screen. Press and hold down to return to the home screen.
4	Switch page - DOWN	Switching between pages, direction down.

#	Name	Function
5	Activation button with start key	The activation button is used to turn the mower on and off. The start key must be inserted before the activation button can be operated.
6	PTO switch	Pull the PTO switch up to activate the mower's cutting blades. Push the switch down to stop the cutting blades.
7	Cutting height adjustment button	Press UP or DOWN to adjust the cutting height.
2 & 4	Screen & lock	To lock and unlock the touch screen (this disables the touch screen's functions), press and hold the UP and DOWN buttons for 3s.

4.1.8 REAR TRAILER HITCH

▲ WARNING

Towing loads can be risky, especially on slopes.

- Max total weight (trailer & load) should not exceed 180 kg.
- Max tongue weight should be under 20.2 kg.
- Avoid slopes over 10 degrees.
- Slow down and be cautious on slopes.
- Do not tow with a grass catcher.

Secure the trailer using the appropriate clevis pin (1) and R pin (2).

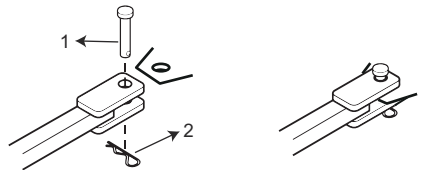

Excessive towed loads affect traction and control on slopes. Lighten the load on slopes. Surface conditions impact traction and stability. Wet or slippery surfaces reduce traction, impacting stopping and turning. Evaluate the terrain before using the unit and trailer, avoiding slopes steeper than 10 degrees.

5 ELECTRICAL SYSTEM

5.1 ELECTRICAL SYSTEM SAFETY

- Always remove the key fob and rotate the service switch to the OFF position before servicing or repairing unit.
- Always rotate service switch to OFF position when transporting unit.

- Keep unit free of grass clippings, leaves and other debris. DO NOT spray water to clean unit. Use only compressed air. Wear adequate eye and hearing protection when cleaning the unit.
- Always wear safety glasses and protective gear near battery. Use insulated tools.
- Clean battery compartment, drive motor compartment, mower deck, etc., of all dirt and debris. Do not use solvents, hard cleaners or abrasives.
- With the mower is ON, mower blade can engage when deck blades ON/OFF switch (PTO) is engaged, even if drive motor is not turning. Keep area clear of bystanders when engaging deck blades ON/OFF switch (PTO).
- Never allow flames, sparks or smoking near batteries.
- Keep batteries out of reach of children.
- Always keep protective shields, covers and guards in place and securely fastened. If they become damaged, repair or replace immediately. Never modify or remove safety devices.

5.2 ELECTRICAL SYSTEM INFORMATION

The product is powered by an 82V electrical system. It consists of the following components:

1. Blade controller (1)
2. Blade motor (3)
3. Drive controller (2)
4. Accelerator - right (1)
5. Accelerator - left (1)
6. Digital display (1)
7. Wheel motor (2)
8. Battery (1)
9. Front light (2)
10. Front fender light (2)
11. Rear light (3)
12. ROPS light (1)
13. ETO socket (2)

6 OPERATION

This section describes how to operate the product.

▲ WARNING

CAREFULLY READ AND UNDERSTAND THE SAFETY CHAPTER AND OPERATION INSTRUCTIONS BEFORE YOU OPERATE THE PRODUCT.

6.1 START THE PRODUCT

Note: Clear the area of bystanders before operating the mower. If anyone enters the mowing area, stop

immediately and do not return to mowing until the bystanders leave the area.

1. Get on the mower from the footrest on both sides of the deck. Accessing the operator's seat from other directions may cause damage to the mower or increase the risk of injury to the operator.
2. Raise the mower deck to its highest position. See **Cutting Height Adjustment** section (Reference 6.2).
3. Insert the start key and press the activation button.
4. Pull steering control levers inward to the NEUTRAL position.

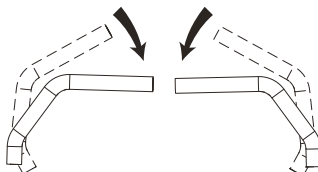

5. Pull up PTO switch to engage blades for mowing.

Note: Engage blades only after steering control levers are moved into the NEUTRAL position. NEVER engage blades when mowing!

6. Push steering control levers forward for forward motion and pull for reverse motion.

Note: Use caution when crossing over gravel paths or driveways. Before crossing, disengage the blades and raise the cutting deck to the highest position to minimize the possibility of ricochet. Drive slowly to avoid loss of traction and control.

Note: Do not attempt to change the direction of operation while the mower is in motion. Always come to a complete stop before changing the mower direction.

Note: Steering control levers will spring back towards the neutral position if released from behind, but it is important to manually guide them to reach the neutral position.

6.2 CUTTING HEIGHT ADJUSTMENT

Before using the mower, raise the deck height to the cutting position best suited for your lawn.

Cutting height is adjustable from 2.5-14 cm. Deck should be raised to avoid stumps, rocks or other obstacle that might damage mower deck.

To adjust the cutting height:

1. Stop the mower and disengage blades.
2. Press the cutting height adjustment button on the control panel to choose a desired cutting height which has 19 levels in total, and each level adjusts 0.6 cm.

6.3 STOP THE PRODUCT

▲ DANGER

Never make sudden stops or reverse direction, especially when maneuvering on a slope. The steering is designed for sensitive response. Rapid movement of the steering control levers in either direction could result in a reaction of the product that can cause serious injury.

1. Drive the mower to a flat, level surface and return the steering control levers to the NEUTRAL position to stop the mower's movement. Push the steering control levers outward to engage the parking brake.

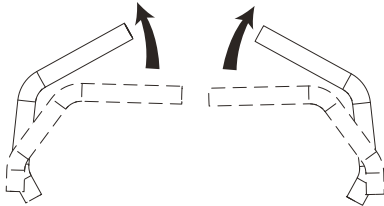

2. Push down PTO switch to disengage the blades.
3. Press the activation button to turn the mower off. Remove the start key.

6.4 DIGITAL DISPLAY

The function of the digital display, located on the control panel, is to provide electrical system information to the operator. It gives detailed information in the form of patterns, codes and numbers.

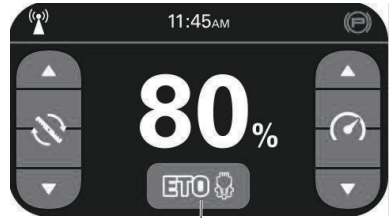
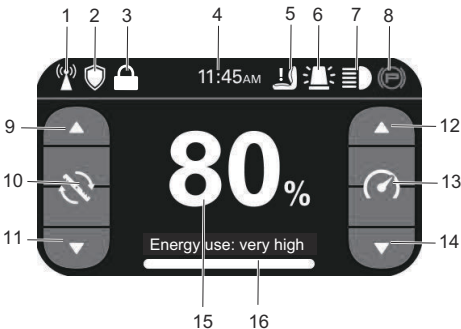

17

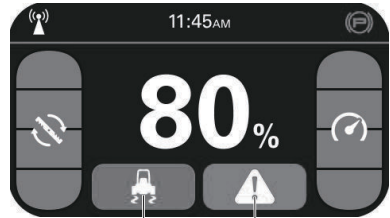





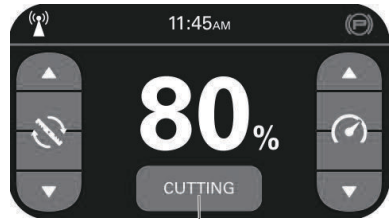











18

19



20

#	Name	Function
1		4G GPS Signal
2		Limp mode is activated.
3		Screen-lock. The touch screen's function is disabled.
4	11:45 AM	Time
5		User presence needed to operate product.
6		Warning light is on.
7		LED Light is on.
8		The parking brake is engaged.
9		Increase blade speed. Each time you touch the screen button, the blade speed will raise a level. When the speed reaches the highest level, the touch button can't adjust any more.
10		Blade speed
11		Decrease blade speed. Each time you touch the screen button, the blade speed will reduce a level. When the speed reaches the lowest level, the touch button can't adjust any more.
12		Increase driving speed. Each time you touch the screen button, the drive speed will raise a level. When the speed reaches the highest level, the touch button can't adjust any more.
13		Driving speed
14		Decrease driving speed. Each time you touch the screen button, the drive speed will reduce a level. When the speed reaches the lowest level, the touch button can't adjust any more.
15	80%	Battery percentage. When it equals to 5% or less, stop work and charge the battery as soon as possible.
16	Energy use	Energy use state
17		ETO button. Touch to control the attachment power.

#	Name	Function
18		Low traction control button. Touch to change to low traction control mode.
19		Error warning. Touch to check the error code and content.
20	CUTTING	Cutting session. Touch to turn to the cutting session page.

6.4.1 SCREEN LOCK

Press and hold the UP and DOWN buttons on the control panel simultaneously for 3 seconds to lock/unlock the screen. When the screen is locked, all the touch operations will be disabled and the home page will show a lock as below.

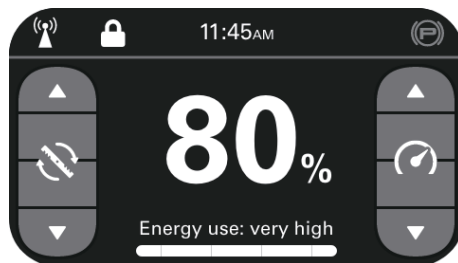

6.4.2 HOME SCREEN STATE

- Both driving speed and blade speed have 4 levels. The number of the green icon at each side indicates the driving speed or blade speed at present.

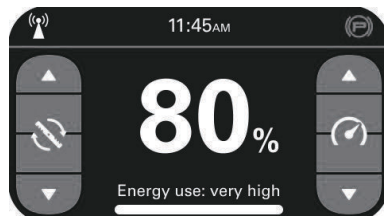

- If the driving/blade system is severely damaged, the driving/blade speed bar will turn grey until the error is cleared.

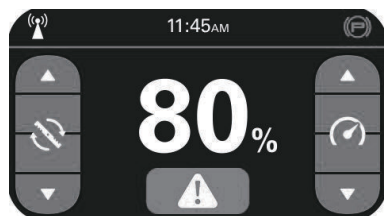

6.4.3 ETO

- When attachments are assembled on the product, the ETO page will show on the screen as below. The ETO power is off when the touch button is grey.

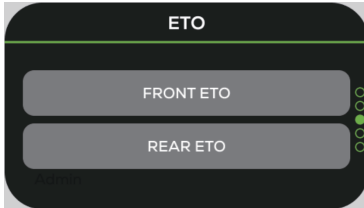

- Touch the ETO button to power on the ETO and the button will turn green.
- Press the Switch Page Button or the Home/back button to return to the home page. The ETO icon will show the ETO power state. Green represents "power on" and grey represents "power off".

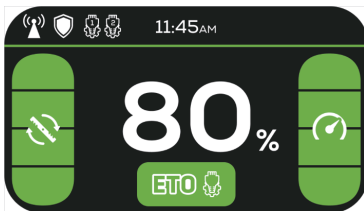

Note: The ETO icon on the home screen only shows the ETO state, can't set the ETO state.

6.4.4 LIGHTS

- Press the Switch Page Button to turn the digital display to the Lights page as below.

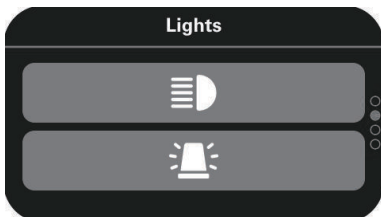

- Press the LED light button to turn on/off the led light. When the LED light button is green, the LED light is ON, and the LED light icon will show on the home screen. When the LED light button is grey, the LED light is off, and the LED light icon on the home screen will disappear.

- Press the warning light button to turn on/off the warning light. When the warning light button is green, the warning light is ON, and the warning light icon will show on the home screen. When the warning light button is grey, the warning light is off, and the warning light icon on the home screen will disappear.

6.4.5 SETTINGS

Press the Switch Page button to go to the Settings page. You can set 6 items including Errors, Statistics, Brightness, Language, Preferences and Low Traction Mode.

Item	Function
Errors	This page shows the error contents and suggestions.
Statistics	This page shows the total work hours, total cut hours, and blade usage time.
Preferences	Select the charging lights, brightness, languages and units of measurement.
Low traction control	Set the low traction mode.
Admin	Select the passcode, speed settings, change the admin PIN and showroom display mode.
Service	Set the steering calibration and show components information.

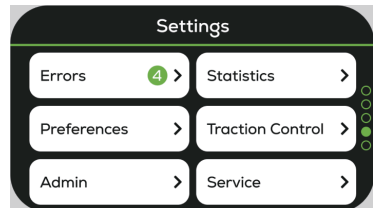

6.4.5.1 ERRORS

Touch the Errors button to enter the Errors page. This page will show all the errors. Touch the specific error name to read the suggestions. Touch "X" to exit.

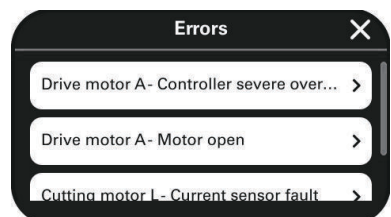

6.4.5.2 STATISTICS

Touch the Statistics button to enter the Statistics page. This page shows the total work hours, total cut hours, and blade usage time. When the blade usage time exceeds 25h, "RESET BLADE" button will turn red from green. Touch the "RESET BLADE" button, the blade usage time will clear to zero and the button will return to green. Touch "X" to exit.

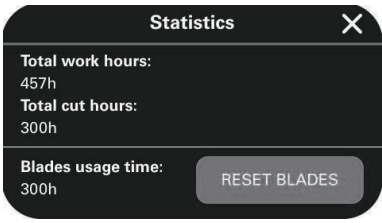

6.4.5.3 PREFERENCES

Touch the Preferences button to enter the Preferences page and set the brightness, languages and units of measurement.

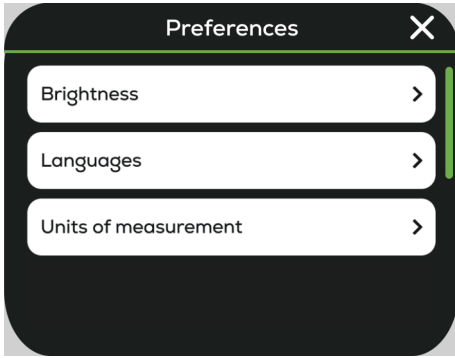

6.4.5.4 TRACTION CONTROL

Touch the Traction Control button to enter the Low traction control page. The low traction control mode button is grey. Touch the button to activate low traction control mode, the button will turn green and the low traction control icon will show on the home screen.

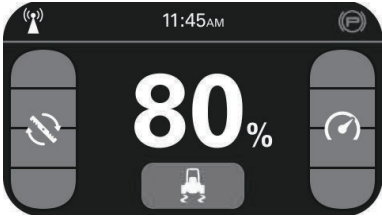

6.4.5.5 ADMIN

Touch the Admin button to enter the Admin page and set the speed, change admin PIN and set the display mode.

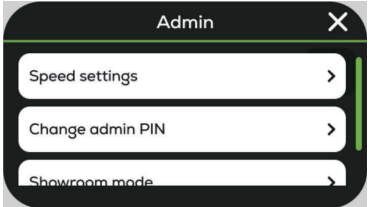

- Set the admin pin when the user opens the page for the first time. Follow the instructions to set the pin. Enter the admin pin every time user open the Speed settings and Showroom mode.
- Touch the Speed Settings button to set the different driving and cutting speed.

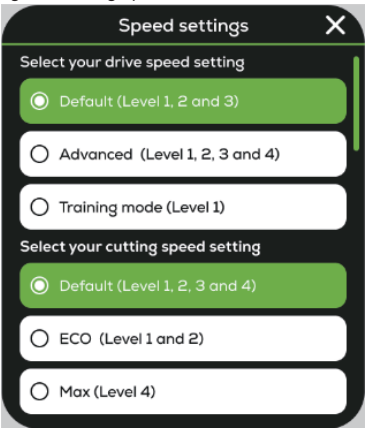

- Touch the Change Admin Pin button to change the admin pin, follow the instructions on the screen to operate.

Note:When the operator can't remember the current admin pin, contact the after-sales service to reset the pin.

- Touch Showroom Display Mode button to select the showroom mode.

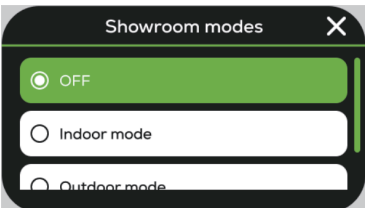

- The wheel and blade motors are disabled when in indoor mode. The wheel motor is abled and the blade motor is disabled when in outdoor mode. The last option will be used if the mower restarts.

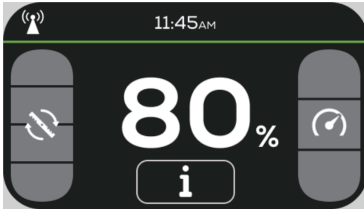

6.4.5.6 SERVICE

Touch the Service button to enter the service page and set the charging lights, brightness, languages and units of measurement.

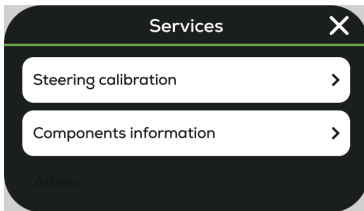

- Touch the Steering Calibration to adjust the tracking by selecting a wheel to reduce its power, test and repeat. Touch "X" to exit.

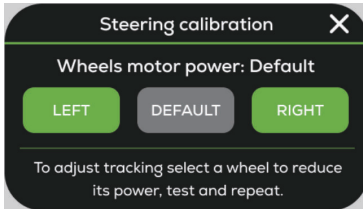

Note: To initiate steering calibration, stop the mower, engage the parking brake and deactivate the blade motors. After the requirements are met, the popup will disappear.

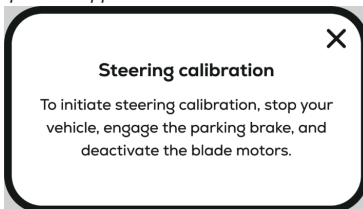

- Touch the Components Information button to view the version of each component. Touch "X" to exit.

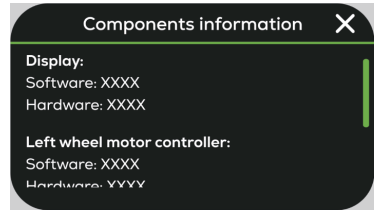

6.4.6 CUTTING SESSION

- When the cutting blade is working, the "CUTTING" button will show on the home screen.

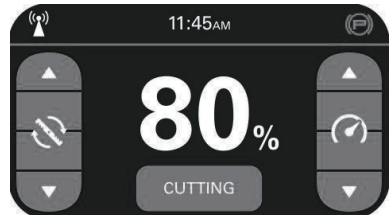

- Touch the "CUTTING" button to enter Cutting session page.

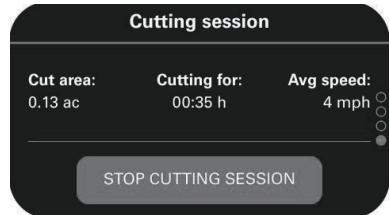

- When the cutting blade stops working, Cutting session data will save for 15 minutes. If the cutting blade restarts working, Cutting session will continue the record.
- Touch the "STOP CUTTING SESSION" button to turn off the cutting session function. The cutting session will be recorded.
- Touch the "START CUTTING SESSION" button to turn on the function.

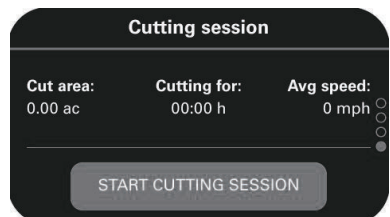

6.4.7 CHARGING

- 1. When the vehicle is charging, the digital display will show the charging screen only. It will shows the battery percentage and the estimated time for fully charged.

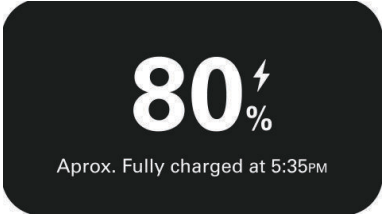

6.4.8 LIMP MODE

- 1. When the battery level is below 5%, the limp mode will be activated. The blade motors will be deactivated and the wheel motors will be reduced to level 1, the mower needs to be charged immediately. And the ETO attachments will shut down automatically.
- 2. A forced limp mode function can be turned on via the App as a security feature to prevent stealing or avoid a stolen product from being used. The function will be activated the next time the product starts.

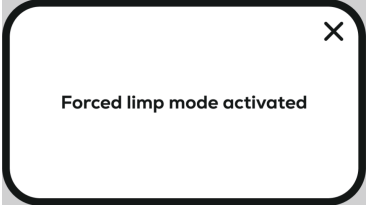

- 3. To deactivated the forced limp mode function, turn off the setting and restart the product.



6.4.9 SOFTWARE UPDATE

- 1. Each time the product starts, it will check if any software update is available. A popup will show if the update is available.

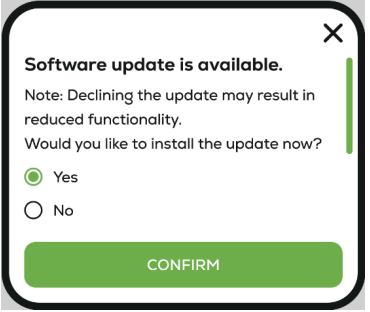

- 2. After the operator confirms, the mower will start the update.
- 3. During the update, a message will be displayed on the screen, reminding the operator not to turn off and stop the mower. The screen will also show an update progress bar and result.

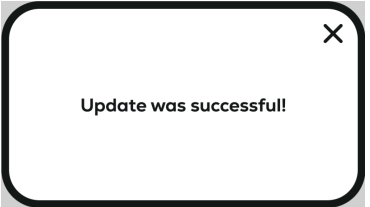
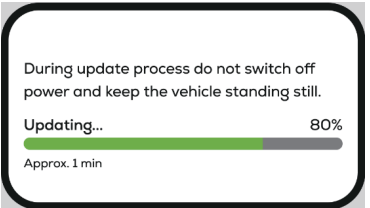

6.5 APP OPERATION TIPS

6.5.1 REGISTRATION AND LOGIN

1. Visit the website of Fleet Management: fleet.greenworkscommercial.com.
2. Create an account and then log in.
3. Invite other users in your organization.
4. Scan the QR code of app below, download the app and log in.



Note: Please reference *Greenworks Commercial App Pairing Page* for more details on connecting your product.

5. Add a device by typing in serial number and pairing code or by scanning QR code on matching label.

Note: The QR code on vehicle matching label on this manual is generated from serial number and pairing code.

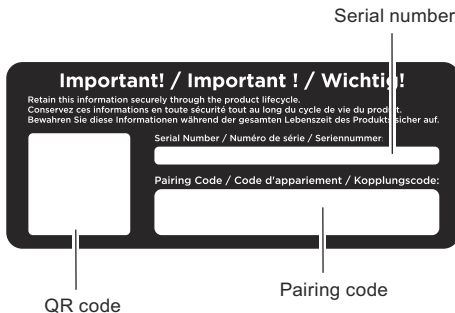

6.6 ZERO-TURN MOWER DRIVING PRACTICE

Prior to operating the mower, ensure you have studied the **Features And Controls** (Reference 4) section to grasp control functions. Using the steering control levers to master smooth and efficient control over forward, reverse, and turning requires practice. Familiarize yourself with acceleration, travel, and steering by practicing maneuvers in a clear, open lawn area, free of obstacles and hazards. Drive at low speeds to prevent tire slippage and lawn damage. Start with the smooth travel procedure and progress through forward, reverse, and turning maneuvers.

6.6.1 SMOOTH TRAVEL

The mower's steering control levers are quick to respond. The optimal approach for managing these handles involves three steps:

1. Place your hands onto the levers.
2. To move forward slowly, push the levers forward with your palms.
3. To reach the maximum of the set speed, move the levers farther forward. For a gentle deceleration, move the levers towards neutral.

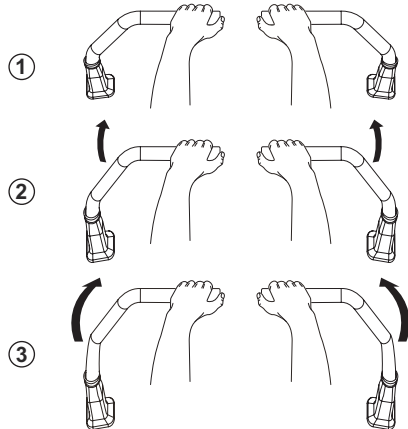

6.6.2 BASIC DRIVING

Forward Travel Practice

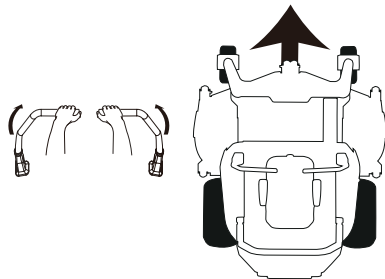

Move both steering control levers evenly and gradually forward from neutral. Practice slowing down and repeating.

Note: Mastering straight forward travel requires practice. Adjust the speed as needed.

Reverse Travel Practice

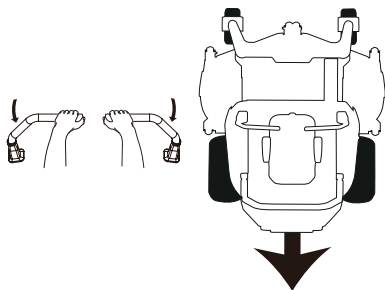

Look behind and down, then gradually pull both steering control levers evenly back from neutral. Practice slowing down and repeating.

Note: Spend several minutes practicing reverse before doing so near objects. Remember, the mower turns sharply in reverse, similar to forward motion, and backing up straight requires practice.

6.6.3 PRACTICE TURNING AROUND A CORNER

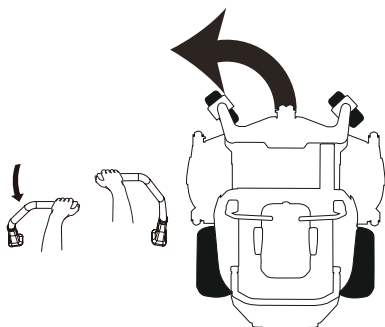

While moving forward, gently bring one steering control lever back towards neutral. Practice this repeatedly.

Note: To prevent pivoting directly on the tire tread, ensure both wheels maintain a slight forward motion.

6.6.4 PRACTICE TURNING IN PLACE

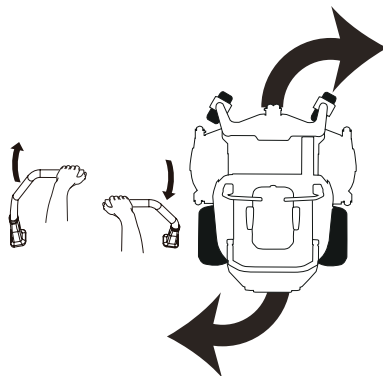

For a "zero-turn" maneuver, gradually move one steering control lever forward from neutral while moving the other handle back from neutral simultaneously. Practice this several times.

Note: Adjusting the extent of pulling each steering control lever forward or back alters the turning "pivot point."

6.6.5 ADVANCED DRIVING

Your zero-turn mower's exceptional feature of turning in place allows you to pivot at the row's end instead of stopping and performing a Y-turn before commencing a new row.

Here's how to execute a left end-of-row zero turn:

1. Gradually decelerate at the row's end.
2. Slightly push the RIGHT steering control lever forward while moving the LEFT steering control lever back to its center and then slightly back.
3. Resume forward mowing.

By adopting this approach, the mower turns left and slightly overlaps the recently cut row, eliminating the necessity to backtrack and recut any missed grass.

6.7 MOWING

Select a smooth, level area to mow. Be cautious of trees, fences, and slopes. Mow in straight lines, slightly overlapping. Occasionally change patterns to prevent flat spots. For a professional touch, mow across once and then go perpendicular on the next round.

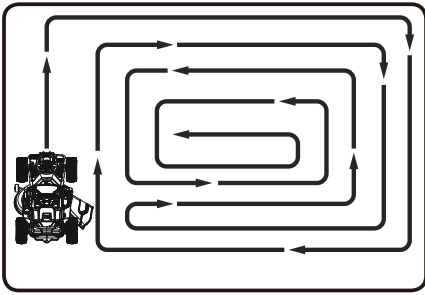

When mowing expansive spaces, begin by turning towards the right to ensure that clippings are directed away from shrubs, fences, driveways, and other areas. After completing one or two rounds, mow in a back-and-forth pattern across the lawn, pivoting at the edges of the previously mowed grass.

6.8 MOWING PATTERNS

6.8.1 SIDE-DISCHARGING

Side-discharging is a mowing technique that efficiently processes a larger volume of grass in a single pass. This method involves expelling grass clippings to the side of the mower deck and dispersing them across the lawn. The side-discharge deck design allows for effective cutting, making it ideal for larger areas where expedited mowing is essential. For optimal mowing, set blade speed to the highest speed (if applicable). If the motor slows, reduce drive speed. Slower drive speed boosts blade efficiency and prevents cutting issues. Choose side-discharging mowing for 75-125 mm grass. Avoid cutting more than 25mm at once.

6.8.2 MULCHING

Mulching offers versatile benefits, finely cutting grass and returning clippings to the soil. Remember, mulching works best on dry and moderate-height grass. For successful mulching, set the blade speed on the highest speed (if applicable) and match it with the slowest driving speed. This ensures finely cut clippings. When mulching, drive at about half the speed used for side discharging.

Optimal Clipping Length

Ideal mulching trims just the top 12-20 mm of grass, resulting in decomposing clippings. Experiment with cutting height based on your climate, season, and lawn thickness. As always, mow thoughtfully and consider your lawn's unique conditions for the best results.

6.9 MOWING RECOMMENDATIONS

Multiple factors impact your mower's grass-cutting efficiency. Adhering to mowing guidelines enhances performance and longevity.

6.9.1 HEIGHT OF GRASS

Cutting height often depends on preference. Typically, mow when grass is 7-12 cm high. Proper height varies based on grass type, rainfall, temperature, and lawn health. Cutting too short weakens grass and makes it prone to damage by dry periods and pests. Slightly longer grass is less prone to damage. Longer growth in hot, dry conditions reduces heat stress, conserves moisture, and guards against damage. Keeping the grass too long leads to thin turf and problems. Don't cut too much at once; follow the 1/3 rule: trim a maximum of 1/3 and no more than 3 cm at a time.

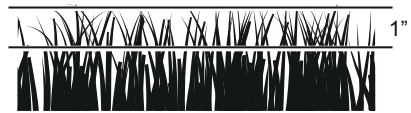
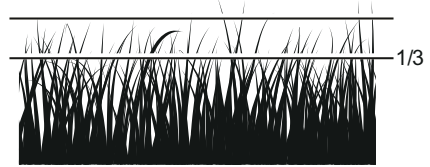

Mowing capacity depends on your chosen mowing system. Broadcasting with side discharge decks handles more grass than mulching. Tall grass needs gradual cutting. For very tall grass, begin with max height (1), then lower it for the second (2) or third pass. Avoid leaving excessive clippings on top of the grass. Consider a grass collection system or composting. Remember, different systems are suited to different situations.

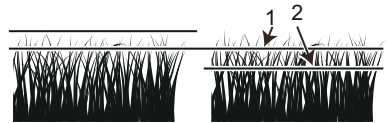

6.9.2 WHEN AND HOW OFTEN TO MOW

The timing and grass condition significantly influence mowing outcomes. Follow these guidelines for best results:

- Mow when grass height is between 75-125 mm.
- Use sharp blades for precision. Short clippings under 25 mm decompose faster, and sharp blades prevent frayed edges.
- Choose a cool and dry time of day for mowing, like late afternoon or early evening.
- Avoid mowing after rain or heavy dew. Never mulch wet grass as it clumps beneath the mower deck and doesn't mulch effectively.

7 TRANSPORTATION

7.1 TRANSPORT THE MOWER

▲ CAUTION

Do not tow this mower, it may cause damage to the drive system.

▲ WARNING

Do not load mower on a trailer or truck using two separate ramps. Only use a full-width ramp that is at least 305 mm (1 ft) wider than the width of the rear wheels of the mower. The rear wheels could fall off the ramps or the unit could tip over injuring the operator or bystanders. Ensure the cutting deck is raised to the highest position so it does not get caught on the ramp.

1. Park the mower on a level surface.
2. Raise the cutting deck to the highest position.
3. Position and secure ramp to the trailer according to manufacturer's instructions.
4. Use a full-width loading ramp that is at least 305 mm (1 ft) wider than the mower to reduce the risk of driving off the side of the ramp.
5. Slowly drive the mower onto the ramp and into the trailer.
6. Set the parking brake.
7. After loading, lower mower deck completely.
8. Secure the mower as needed using straps or cables to prevent movement during transport.

▲ WARNING

To avoid accidental starting or movement that could result in serious personal injury, always remove the start key and engage the parking brake when transporting the mower.

7.2 NEUTRAL BYPASS LEVER

The neutral bypass levers disengage the drive system that connects the engine power to the wheels and may be used when you need to manually push or move the mower without the engine running.

- Locate the neutral bypass levers situated underneath the rear of the mower's frame. These levers individually manage the drive wheels.
- Push the lever outwards to unlock the levers to release the drive brakes.

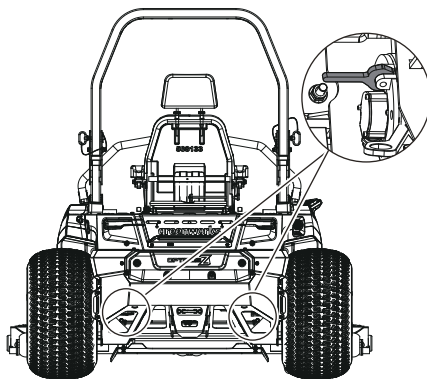

- Push the lever inward to lock the levers for regular operation.

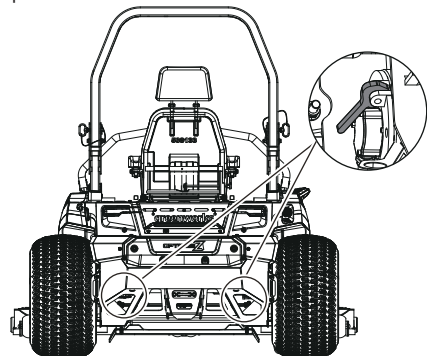

▲ WARNING

Never drive mower with the neutral bypass lever disengaged. Always engage the neutral bypass lever to the original position before driving! Failure to engage the lever could cause serious damage to your mower and void mower warranty!

▲ WARNING

Never unlock the neutral bypass levers when the mower is on a slope. Once the levers are released, the mower can roll freely and does not have a brake. Releasing the lever on a slope could lead to loss of control and increase the risk of serious personal injury.

7.3 MOVE THE MOWER MANUALLY

To push the mower manually:

1. Disengage the blades and push the steering control levers outward to engage the parking brake.
2. Turn the start key to the OFF position. Remove the start key, and wait for all moving parts to stop before leaving the operating position.

3. Return the steering control levers to the NEUTRAL position then unlock the neutral bypass levers to disengage the drive system.
4. Move the mower to the desired location.

▲ CAUTION

To avoid damage to the motor and drive system, do not move the product faster than 8 km/h.

5. Immediately after moving the mower, lock the neutral bypass levers.

8 CLEAN AND STORAGE

8.1 CLEAN THE PRODUCT

- Remove any build-up of grass and leaves on or around the motor cover (Do not use water).
- Occasionally wipe the mower clean with a dry cloth.
- If debris builds up on the underside of the mower during use, stop the motor on level ground, disengage the blades, set the parking brake, shut off the product, remove the start key and use the compressed air to clean the area.

8.2 STORE THE PRODUCT

The following steps should be taken in order to prepare the product for storage.

- **Clean the Mower:** Before storing the product, thoroughly clean it as outlined in the previous section.
- **Blade Inspection and Maintenance:** Inspect the blades and replace them as detailed in the **Service**

9 MAINTENANCE

9.1 MAINTENANCE SAFETY

- Specific steps must be taken in order to perform service and maintenance procedures safely.
- Read and follow all the applicable safety and instructional messages in this manual.
- Always disengage the mower blades, set the parking brake, shut the mower off, remove the start key, turn the service switch to OFF position and wait for all movement to stop prior to performing service and maintenance procedures.
- Wear appropriate personal protective equipment such as safety shoes, safety glasses, gloves and ear protection. Long hair, loose clothing or jewelry may get tangled in moving parts. Secure hair above shoulder level before starting work.
- Use of parts that are not authorized or approved by Greenworks may cause serious or fatal injury or property damage.

9.2 BATTERY MAINTENANCE

The mower is powered by Lithium-Ion batteries which, when maintained properly, will provide years of useful life. For proper care, adhere to the following instructions:

- Always charge battery after each use. This is especially crucial when temperatures drop below 0°C. Over-discharge will shorten battery life and risk permanent damage. If a full charging cycle is not possible immediately after cutting, a 5-10 minute cycle will help maintain battery health. Fully re-charge the battery within 24 hours after use. To maintain proper calibration, run and charge the mower at least once a month. Complete a full charge every six months.

the Mower Blades (Reference 9.8) section if needed.

- **Avoid Corrosive Materials:** Keep the mower away from corrosive substances, such as fertilizer or rock salt, as these can lead to rust and corrosion on metal components like the blade, deck, motor, and frame. Keep the mower and its battery away from conductive or corrosive materials to reduce the risk of short circuit, fire, explosion and other electrical hazards.
- **Children Safety:** Store the product in a location inaccessible to children to prevent accidents.
- **Proper Covering:** Do not cover the product with a solid plastic sheet. Plastic coverings can trap moisture, which causes rust and corrosion.
- **Check for Wear and Tear:** Thoroughly inspect the mower for any worn or damaged parts that may require replacement.
- **Tire Maintenance:** Avoid deflating the tires during storage.
- **Storage Environment:** Store the product in a well-ventilated, clean, and dry area. Note that the battery charger cannot be used in a wet environment.
- **Charging Process:** Refer to the **Charging** (Reference 9.3) section and also the Battery Charger Manual for comprehensive instructions on using the charger and effectively charging the battery.

Note: By adhering to these guidelines, you can help increase the longevity of your mower during periods of storage.

- Keep grass, dirt and debris from collecting in battery area.
- Charge battery in an enclosed, dry area away from sparks and flames. Never expose charger to rain, water vapor or other liquids.
- Do not touch uninsulated portion of charger (terminal pins) or output connector.
- Do not use charger if cords are damaged.
- Please refer to the Battery Manual for more information of batteries.

9.2.1 ROUTINE MAINTENANCE

Routine maintenance should include cleaning and inspection.

- During the battery charging process:
 - Make sure the charging plug connects securely and fully in the socket;
 - Make sure the charger operates without faults;
 - Address any faults and have them repaired before charging.
- During the operation of the mower and when charging the battery, keep the charging port away from water and other conductive materials. Never charge when the mower is wet.
- Charging time will depend on a number of factors, including battery health, ambient temperatures and other factors. Monitor the battery for abnormal performance or behavior.

9.3 CHARGE THE PRODUCT

1. The battery charging port is located on the left (with operator seated) back housing of the mower. Open the charging flap, and press the release button to open the port cover to charge.
2. Plug the charger into the battery charging port, and make sure it is firmly plugged in.
3. Plug the charger into a power outlet, and make sure it is firmly plugged in.
4. When the mower is charging, the digital display will show the battery percentage.

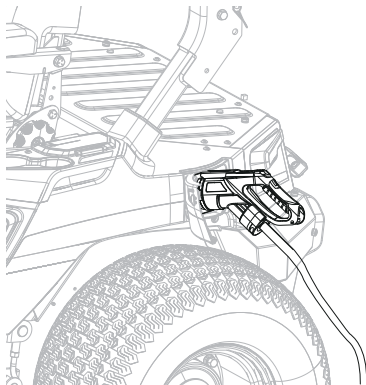

▲ WARNING

See the Battery Charger Manual for warnings and instructions for charging. Read and understand all its safety warnings and instructions. Failure to follow them may result in electrical shock, fire and/or serious injury.

▲ WARNING

To reduce the risk of fire and explosion, keep open flames and sparks away from the mower and its batteries. Ensure proper ventilation around the mower while charging.

Charging recommendations:

- The battery does not need to be fully discharged before recharging. To maintain proper state of charge calibration, run and charge the mower at least once a month. Complete a full charge every six months.

- A battery left uncharged will slowly discharge. Before initial use each spring season, be sure battery has a full charge before mowing.
- Check the battery every six months and charge the battery if the power level is below 50%.
- When the battery level is at 5%-10%, the max driving speed will be 9.6 km/h. When the battery level is lower than 5%, the blade motor will stop automatically, and the mower needs to be charged immediately.

Note: Cover the battery charging port with the port cover before mowing to prevent foreign objects from entering and causing any damage to the port.

9.4 RECOMMENDED MAINTENANCE SCHEDULES

Maintenance Service Interval	Maintenance Procedure
Before each use or daily	<ul style="list-style-type: none"> • Check the safety interlock system as mentioned in Safety Start Interlock System section (Reference 2.4.12). • Check the roll over protection system (ROPS) as mentioned in Roll Over Protection System section (Reference 2.4.10). • Check the seat belt as mentioned in Inspect The Seat Belt section (Reference 2.4.10). • Inspect the blades. • Check for frayed and deteriorated insulations. • Check the contacts of all switches and brakes. If the P icon will show on the LED display screen, the brakes have no error. • Clean under the cutting deck. Clean the area under the operator's seat and near the battery. Remove all grass clippings, leaves, and debris from the product before starting work.
Every 25 hours	<ul style="list-style-type: none"> • Lubricate the front casters and the front wheel hubs.
Every 50 hours	<ul style="list-style-type: none"> • Check the tire pressure.
Every 100 hours	<ul style="list-style-type: none"> • Check the wheel-lug nuts.
Before storage	<ul style="list-style-type: none"> • Remove the start key from the product and turn the service switch to OFF position. • Perform all maintenance procedures listed above and thoroughly clean the product. • Inspect the entire product for damaged, missing, or loose parts, replace or tighten the corresponding ones before storage. • Paint chipped surfaces.

9.5 LUBRICATION

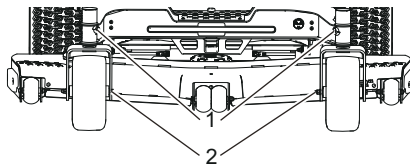

Use a general purpose lithium-based grease to lubricate the grease fittings (1) (2) on both front casters and the front wheel hubs. Grease the front wheel hubs and the front casters every 25 hours.

9.6 CHECK TIRE PRESSURE

Tire pressure should be checked periodically, and maintained at the levels shown below. Notice that these recommendations may differ slightly from the "Max Inflation" stamped on the side-wall of the tires. Exceeding the max inflation will lead to a tire explosion. The pressures shown provide proper traction and extend tire life.

Drive wheels	18-20 psi
--------------	-----------

9.7 TORQUE VALUES

▲ WARNING

Particular attention must be given to tightening the drive wheel lug nuts and blade spindle bolts. Failure to correctly torque these items may result in the loss of a wheel or blade, which can cause serious damage and/or personal injury.

Torque values are given below:

Part	N.m
Wheel lug nuts	95-105
Blade spindle bolts	160

Wheel lug nuts only: It is recommended that these be checked after the first 2 hours of operation initially, then every 100 hours and following removal for repair or replacement.

9.8 SERVICE THE MOWER BLADES

9.8.1 MOWER BLADE MAINTENANCE

Check the mower blades daily. They are the key to power efficiency and well-groomed turf. Keep them sharp -- a dull blade will tear rather than cut the grass, leaving a brown ragged top on the grass within a few hours. A dull blade also requires more power. Replace any blade that is bent, cracked or broken.

▲ WARNING

Never attempt to straighten a bent blade by heating, or weld a cracked or broken blade as the blade may break and cause serious injury. Replace worn or damaged blades.

▲ WARNING

Never work with blades while key is in the ignition switch. Press push button to turn the mower OFF, remove key fob from switch and rotate service switch to OFF position. Block up mower when you must work under it. Wear gloves when handling blades. Always check for blade damage if mower strikes a rock, branch or other foreign objects!

▲ DANGER

The blade adapter will come off when the blade cap screw is removed. Touch-up sharpening can be done with a file. Check the blades for balance following grinding. A commercial balancing tool is available through most hardware supply stores, or balancing can be done by placing the blade on an inverted line punch or 13 mm (1/2") bolt. Blade should not lean or tilt. While spinning the blade slowly, it should not wobble. If blade is out of balance, true it up before reinstalling. Lay the blade on a flat surface and check for distortion. Replace any distorted blade.

▲ WARNING

- The blade sail (curved part) must be pointing upward toward the inside of the deck to ensure proper cutting.
- When mounting blades, rotate them after installation to ensure blade tips do not touch each other or sides of the mower.
- Failure to correctly torque the bolt may result in the loss of the blade, which can cause serious injury.
- Mower blades are sharp and can cut. Wear gloves and use extra caution when servicing them.

9.8.2 REMOVE THE MOWER BLADES

▲ WARNING

Mower blades are sharp. Always wear gloves when handling or working near mower blades.

1. Park the mower on a flat level surface, disengage the PTO and pivot the steering control levers outward to engage the parking brake. Shut off the mower, remove the start key and turn the service switch to OFF position.

- Use a jack stand to lift the front of the mower chassis upward for easier access to the blades. The jack stand can be put against the front hitch. Ensure the mower is secure before working underneath it.

▲ WARNING

Make sure the mower is secured when it is lifted by the jack stand and while working on it.

- Place a block of wood between the blade and the deck to prevent it from spinning while you work.
- Loosen the left and middle mulching blade bolt (from the operator's perspective) by rotating counterclockwise with a 24 mm socket or wrench. Loosen the right cutting blade bolt (from the operator's perspective) by rotating clockwise with a 24 mm socket or wrench.

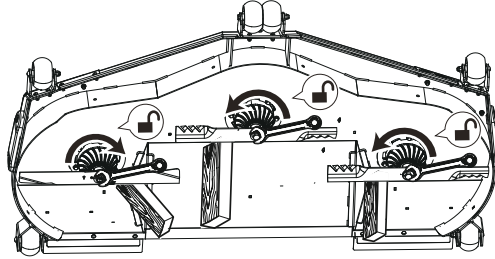

- Remove the blade bolt, spacer, blade, and blade support.

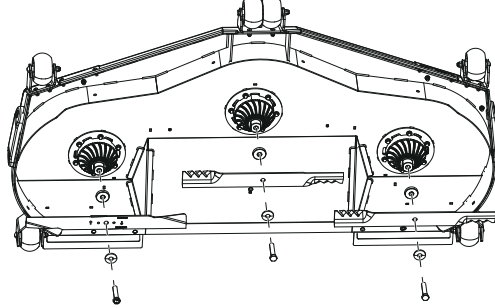

9.8.3 INSPECT THE MOWER BLADES

A worn or damaged mower blade has the potential to break, leading to fragments being propelled into the operator's or bystander's area, causing severe personal harm or death. Inspect it before each use. Halt operation if the mower hits an object and inspect for damage.

▲ WARNING

Mower blades are sharp. Always wear gloves when handling or working near mower blades.

- Remove the mower blade from the mower. See **Remove the Blades** (Reference 9.8.2).
- Inspect the mower blades to assess whether they are blunt and require sharpening or display signs of damage and should be replaced. Blades showing cracks, corrosion, rust, excessive wear or bending should be discarded.

9.8.4 INSTALL THE MOWER BLADES

▲ WARNING

Mower blades are sharp. Always wear gloves when handling or working near mower blades.

- Install the new blades following the specified sequence: blade support, blade, spacer, and blade bolt. Ensure that the blade sail (curved part) is pointing upward toward the inside of the deck.

▲ WARNING
Incorrect orientation of the blades can damage the cutting deck and impact the mower's stability which can affect operator's safety.

- 2. Securely tighten the left and middle mulching blade bolts (from the operator's perspective) by rotating clockwise and tighten the right cutting blade bolts (from the operator's perspective) by rotating counterclockwise with a 24 mm socket or wrench. Torque to 160 N.m.

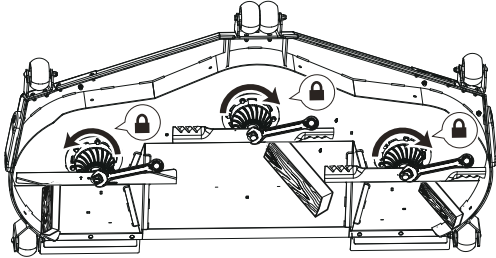

10 TROUBLESHOOTING

PROBLEM	POSSIBLE CAUSE	CORRECTIVE ACTION
Product won't move.	Battery power is low.	Check the battery power, if the battery power is low, charge the battery.
	Steering control levers are in the parking position.	Make sure that both the left and right steering control levers are not in the parking position.
	No one is sitting on the seat or the operator presence switch is not functioning properly.	Make sure the driver is sitting on the seat.
	When powered on, the left and right parking switches are not in their initial positions.	Place steering control levers in the initial position and restart the product. If it still can't start, please contact official Greenworks after-sales service center.
	The battery compartment is in dormant state.	Turn the start key to the OFF position and wait for more than 5 seconds before restarting the product.
Product suddenly stops during driving.	Battery is not charged.	Use only official Greenworks battery (batteries). At least one fully-charged battery is required for operation.
	Driving on rough and uneven road conditions cause the operator presence switch to disconnect.	Place the steering control levers in the initial position, restart the product, push the steering control levers.
	Accelerator failure.	Contact Greenworks after-sales service center.
	Vehicle controller failure.	Contact Greenworks after-sales service center.
The blade does not operate after pulling the PTO switch.	There is no battery installed in the battery compartment or the battery is not an official Greenworks battery.	Use only official Greenworks battery (batteries). At least one fully-charged battery is required for operation.
	The battery power is lower than 5%.	Check the battery power, if the battery power is low, charge the battery.
	The operator presence switch is not functioning properly.	Ensure the driver is sitting on the seat.
	The blade switch (PTO) is not in the correct position before powering on.	Push the PTO and pull it up again.
	Blade motor blockage or other functional protection.	Make sure there are no weeds or foreign objects at the connection point between the blade and the motor. It is recommended to raise the deck and start the blade to ensure normal operation before adjusting the deck height.
	Drive controller malfunction	Check the error code on display screen. Contact Greenworks after-sales service center.
The blade stops when mowing grass.	Blade controller malfunction	Check the error code on display screen. Contact Greenworks after-sales service center.
	Blade motor overload.	Clean the inside of the deck, make sure there is no abnormal blade rotation, press the PTO switch, restart the product and reduce the blade load, either by raising the cutting deck or reducing the driving speed.
	Battery temperature is too high.	Do not use the product immediately after charging, otherwise it may trigger the battery temperature protection error.
	The battery power is lower than 5%.	Check the battery power, if the battery power is low, charge the battery.

PROBLEM	POSSIBLE CAUSE	CORRECTIVE ACTION
	The blade is hit by a foreign object, causing a sudden stop.	Turn the start key to the OFF position and wait for more than 5 seconds before restarting the product.
	Drive controller malfunction	Check the error code on display. Contact greenworks after-sales service center. Contact Greenworks after-sales service center.
The mower cuts the grass unevenly, and the height difference is very large.	The blade is blunt.	Contact the Greenworks after-sales service center to sharpen or replace the blades.
	Blade is bent.	Replace the blade according to the manual instructions, and wear protective gears.
	Uneven deck.	Contact the Greenworks after-sales service center to level the deck.
The actual mowing height does not match the marked mowing height chosen.	Deck mounting bolts are loose.	Securely tighten deck mounting bolts. The deck needs to be re-leveled after adjusting the mounting bolts.
	The deck is seriously worn or damaged.	Contact the Greenworks after-sales service center to replace the deck.
Abnormal product shredding	The grass is too wet.	Wait until grass is dry.
	The grass is too tall/dense.	Raise the deck and cut grass with multiple passes, adjusting the height accordingly.
Excessive product vibration	Blade bolts are loose.	Contact the Greenworks after-sales service center to sharpen or replace the blades..
	Blade is bent.	Replace the bent blade according to the manual instructions, and wear protective gears.
	Uneven deck.	Contact the Greenworks after-sales service center to level the deck.
	Deck mounting bolts are loose.	Securely tighten deck mounting bolts. The deck needs to be re-leveled after adjusting the mounting bolts.
	The grass is too tall/dense.	If the grass is too dense and high, please raise the deck, try to avoid cutting heavy grass.
Grass leaves or debris left on the ground after mowing.	The grass is too tall/dense.	Raise the deck and cut grass with multiple passes, adjusting the height accordingly. If the grass exceeds 6 inches, please use two mowing cycles to achieve the mowing effect. Try to avoid cutting heavy grass as much as possible.
	The grass is too wet.	Wait until grass is dry.
	Driving speed is too high.	Lower the driving speed.
	Blade cutting speed is too low.	Increase the blade speed.
Short mowing duration	Grass is too tall/dense.	Raising the deck or decrease blade speed to increase the mower's usage time on one charge.
Mower running deviation	Different tire pressure	Check the rear tire pressure of the product regularly according to the manual instructions.
Product won't start after washing.	Improper cleaning, leading to water entering: the digital display screen, battery compartment, and/or other electronic components.	<ol style="list-style-type: none"> 1. Follow the instructions to clean the product. 2. If the product is accidentally drenched, store the product in a dry place for 12 hours or blow dry before restarting. 3. Contact Greenworks after-sales service center if the problem persists.

PROBLEM	POSSIBLE CAUSE	CORRECTIVE ACTION
The mower is blocked.	Weeds and debris build up on the deck.	Follow the manual instructions to clean the product after each use.
Product with parking brake slides on slope.	Severe tire wear.	Contact the Greenworks after-sales service center to replace the tires.
	The parking brake is damaged or terribly worn.	Contact the Greenworks after-sales service center to replace the parking brake.
	The parking brake is manually released.	Check the parking brake and reset it to the initial position.

11 TECHNICAL DATA

Model No.	OZ972R	
Voltage	82 V	
Length	221.4 cm	
Height	189.5 cm	
Width (with discharge chute)	187.2 cm	
Cutting width	182 cm	
Driving speed	Forward	9.6/14.4/19.2/22.4 km/h
	Reverse	4.8/6.4/8/8 km/h
Blade speed	2450/2600/2750/2900 RPM	
No load speed	2900 RPM	
Charger model	CV30KWC, 2960907AU	

The recommended ambient temperature range:

Product storage temperature	0 °C ~ 35 °C	
Product operation temperature	-20 °C ~ 40 °C	
Battery pack storage temperature	within 4 weeks	-20°C ~ 45°C
	4 weeks to 52 weeks	0 °C ~ 35 °C
Charger operation temperature	-20 °C ~ 50 °C	
Battery pack charging temperature	0 °C ~ 55 °C	
Battery pack discharging temperature	-20 °C ~ 55 °C	

12 WARRANTY

Greenworks hereby warranties this product, to the original purchaser with proof of purchase, for a period of 5 Years, 2000 Hours for unit and battery, 2 years on charger. (commercial usage). Greenworks, at its own discretion, will repair or replace any and all parts found to be defective, through normal use, free of charge to the customer. This warranty is valid only for units which have been used for personal use that have not been hired or rented for industrial/commercial use, and that have been maintained in accordance with the instructions in the owners' manual supplied with the product from new.

13 ERRORS

The Canbus system will take action to protect the user and product when it detects an issue. When it acts to turn off the product or a component, it will indicate that an error has occurred, and that error will be shown on the digital

display. All electrical errors have a letter code followed by a number. The first letter describes the system that caused the error according to this chart:

Name	Meaning
BMS	Battery error code
BC	Battery charger error code
TR	Right wheel motor controller error code
TL	Left wheel motor controller error code
ML	Left blade motor controller error code
MM	Middle blade motor controller error code
MR	Right blade motor controller error code
DS	Display screen error code
LA	Deck linear actuator error code

13.1 DISPLAY SCREEN ERROR CODE

Fault Codes	Fault Contents	User's Operation Suggestions
DS 11	Abnormal Display CAN Communication	1. Please check the maintenance switch is set to "I" / ON condition. 2. Please check if the CAN wire on the display or the right wheel motor controller is well connected. 3. Please restart the vehicle. 4. If fault persists after completing the above inspections, please contact after-sales service.
DS 12	Right Wheel Controller CAN Communication Abnormal	1. Please check the maintenance switch is set to "I" / ON condition. 2. Please check if the CAN wire on the display or the right wheel motor controller is well connected. 3. Please restart the vehicle. 4. If fault persists after completing the above inspections, please contact after-sales service.
DS 13	BMS CAN Communication Abnormal	1. Please check if the CAN wire on the Battery is well connected. 2. Please restart the vehicle. 3. If fault persists after completing the above inspections, please contact after-sales service.

13.2 BMS ERROR CODE

Fault Codes	Fault Codes	User's Operation Suggestions
BMS 11	Battery Discharging Slight Overtemp	Vehicle has been put into a state of reduced performance while cooling. Once temperature is back within standard range, the fault will automatically clear and normal operation will resume.
BMS 12	Battery Discharging Severe Overtemp	Vehicle has been disabled while cooling. Once temperature is back within standard range, the vehicle can be restarted to clear the fault and resume operation.
BMS 13	Battery Discharging Slight Under-temp	Vehicle has been put into a state of reduced performance while warming. Once temperature is back within standard range, the fault will automatically clear and normal operation will resume.
BMS 14	Battery Discharging Severe Under-temp	Vehicle has been disabled while warming. Warming can take up to 6 hours. Once temperature is back within standard range, the vehicle can be restarted to clear the fault and resume normal operation.
BMS 15	Battery Cells Slight Temperature Difference	Vehicle has been put into a state of reduced performance while cell temperatures return to normal. Once temperature is back within standard range, the fault will automatically clear and normal operation will resume.
BMS 16	Battery Cells Severe Temperature Difference	Vehicle has been disabled while cell temperatures return to normal. This can take up to 6 hours. Once temperature is back within standard range, the vehicle can be restarted to clear the fault and resume operation.
BMS 17	Battery Cells Slight Overvoltage	Please stop charging. This action should correct and clear the fault automatically. If fault persists please contact after-sales service. Vehicle is put into a state of reduced performance while fault is present.
BMS 18	Battery Cells Severe Overvoltage	Please stop charging. If this action does not correct the fault please contact after-sales service and discontinue use of the vehicle. Vehicle is disabled while fault is present.
BMS 19	Battery Cells Slight Undervoltage	Please stop using the vehicle and begin charging. Once vehicle has been charged and cell voltage is within standard range, the fault will automatically clear. The vehicle is put into a state of reduced performance while fault is present.
BMS 21	Battery Cells Severe Undervoltage	Please stop using the vehicle and begin charging it. If this action does not correct the fault please contact after-sales service and discontinue use of the vehicle. Vehicle is disabled while fault is present.
BMS 23	Insulation Resistance Severe Insufficient	Please discontinue use of the vehicle, and contact after-sales service to check vehicle insulation. Vehicle is disabled while fault is present.

Fault Codes	Fault Codes	User's Operation Suggestions
BMS 24	Battery Discharge Slight Overcurrent	Vehicle has been put into a state of reduced performance while discharge current high. Attempt to reduce vehicle load. Once current is back within standard range, the fault will automatically clear and normal operation will resume.
BMS 25	Battery Discharge Severe Overcurrent	Vehicle has been disabled. Attempt to reduce vehicle load. Once discharge current is back within standard range, the vehicle can be restarted to clear the fault and resume operation. If fault persists contact after-sales service.
BMS 26	Battery Cells Voltage Slight Difference	Please charge vehicle. This action should correct and clear the fault. If fault persists contact after-sales. Vehicle has been put into a state of reduced performance while cell voltages are different.
BMS 27	Battery Cells Voltage Severe Difference	Please discontinue use of the vehicle and begin charging. If fault persists after this action contact after-sales. Vehicle is disabled while fault is present.
BMS 28	Battery Slight Overvoltage	Please stop charging. This action should correct and clear the fault automatically. Vehicle is put into a state of reduced performance while fault is present.
BMS 29	Battery Severe Overvoltage	Please stop charging. If this action does not correct the fault please contact after-sales service and discontinue use of the vehicle. Vehicle is disabled while fault is present.
BMS 31	Battery Slight Undervoltage	Please charge vehicle. This action should correct and clear the fault automatically. If fault persists contact after-sales. Vehicle has been put into a state of reduced performance while cell voltages are different.
BMS 32	Battery Severe Undervoltage	Please discontinue use of the vehicle, and begin charging. If fault persists after this action contact after-sales. Vehicle is disabled while fault is present.
BMS 33	Battery Charging Slight Overtemp	Charging performance reduced while temperature is high. Once temperature is within standard range fault will automatically clear and normal charging operation will resume.
BMS 34	Battery Charging Severe Overtemp	Please stop charging and allow unit to cool down. If this action does not correct the fault discontinue use and contact after-sales service.
BMS 35	Charging Port Slight Overtemp	Charging performance reduced while temperature is high. Once temperature is within standard range fault will automatically clear and normal charging operation will resume.
BMS 36	Charging Port Severe Overtemp	Please stop charging and allow charge port to cool down. Check for any debris that may be in charging port

Fault Codes	Fault Codes	User's Operation Suggestions
		or plug and clear if present. If this action does not correct the fault discontinue use and contact after-sales service.
BMS 37	Discharging B+ Contactor Welded	Please restart vehicle. If fault persists, contact after-sales service and discontinue use of the vehicle. Vehicle is disabled while fault is present.
BMS 38	Battery B- Contactor Welded	Please restart vehicle. If fault persists, contact after-sales service and discontinue use of the vehicle. Vehicle is disabled while fault is present.
BMS 39	Battery Charging Contactor Welded	Please restart vehicle. If fault persists, contact after-sales service and discontinue use of the vehicle. Vehicle is disabled while fault is present.
BMS 41	Battery Heater Contactor Welded	Please restart vehicle. If fault persists, contact after-sales service and discontinue use of the vehicle. Vehicle is disabled while fault is present.
BMS 42	Battery Current Sensor Abnormal	Please restart vehicle. If fault persists, contact after-sales service and discontinue use of the vehicle. Vehicle is disabled while fault is present.
BMS 43	Battery Sampling Chip Abnormal	Please restart vehicle. If fault persists, contact after-sales service and discontinue use of the vehicle. Vehicle is disabled while fault is present.
BMS 44	Battery Cell Open Circuit	Please restart vehicle. If fault persists, contact after-sales service and discontinue use of the vehicle. Vehicle is disabled while fault is present.
BMS 45	Master and Slave chips Abnormal	Please restart vehicle. If fault persists, contact after-sales service and discontinue use of the vehicle. Vehicle is disabled while fault is present.
BMS 47	Charger CAN Communication Time-out	Please attempt to reinsert and ensure charging connector is fully seated. Ensure use of a known good charger. If these actions for not correct the fault, discontinue use of the vehicle and contact after-sales service.
BMS 48	Battery Precharge Failed	Please restart vehicle. If fault persists, contact after-sales service and discontinue use of the vehicle. Vehicle is disabled while fault is present.
BMS 49	Battery 12V Abnormal	Please restart vehicle. If fault persists, contact after-sales service and discontinue use of the vehicle. Vehicle is disabled while fault is present.
BMS 51	Battery Heater Abnormal	Please restart vehicle. If fault persists, contact after-sales service and discontinue use of the vehicle. Vehicle is disabled while fault is present.
BMS 52	Battery CC2 Detection Abnormal	Please attempt to reinsert and ensure charging connector is fully seated. Ensure use of a known good charger. Check for any debris that may be in charging port or plug and clear if present. If these actions for not correct

Fault Codes	Fault Codes	User's Operation Suggestions
		the fault,discontinue use of the vehicle and contact after-sales service.
BMS 53	Battery B+ Contactor Coil Short	Please restart vehicle. If fault persists, contact after-sales service and discontinue use of the vehicle. Vehicle is disabled while fault is present.
BMS 54	Battery B- Contactor Coil Short	Please restart vehicle. If fault persists, contact after-sales service and discontinue use of the vehicle. Vehicle is disabled while fault is present.
BMS 55	Battery Precharge Contactor Coil	Please restart vehicle. If fault persists, contact after-sales service and discontinue use of the vehicle. Vehicle is disabled while fault is present.
BMS 56	Battery Charge Contactor Coil Short	Please restart vehicle. If fault persists, contact after-sales service and discontinue use of the vehicle. Vehicle is disabled while fault is present.
BMS 57	Battery Heating Contactor Coil Short	Please restart vehicle. If fault persists, contact after-sales service and discontinue use of the vehicle. Vehicle is disabled while fault is present.
BMS 58	Battery Continuous Discharge Over-current	Vehicle has been put into a state of reduced performance while discharge current high. Attempt to reduce vehicle load. Once current is back within standard range, the fault will automatically clear and normal operation will resume.

13.3 BATTERY CHARGER ERROR CODE

Fault Codes	Fault Contents	User's Operation Suggestions
BC 11	Input Power Undervoltage	Please stop charging and restart charger. Ensure use of a known good charger. If these actions do not correct the fault, contact after-sales service.
BC 12	Input Power Overvoltage	Please stop charging and restart charger. Ensure use of a known good charger. If these actions do not correct the fault, contact after-sales service.
BC 13	Output Undervoltage	Please stop charging and restart charger. Ensure use of a known good charger. If these actions do not correct the fault, contact after-sales service.
BC 14	Output Overvoltage	Please stop charging and restart charger. Ensure use of a known good charger. If these actions do not correct the fault, contact after-sales service.
BC 15	Output Overcurrent	Please stop charging and restart charger. Ensure use of a known good charger. If these actions do not correct the fault, contact after-sales service.
BC 16	Charger Overtemp	Charger performance reduced while temperature is high. Once temperature is within standard range fault will automatically clear and normal charging operation will resume.
BC 17	Output Short Circuit	Please discontinue charging. Ensure use of a known good charger. If this does not correct the fault, contact after-sales service.
BC 18	Battery Output Polarity Reversal	Please discontinue charging. Ensure use of a known good charger. If this does not correct the fault, contact after-sales service.
BC 19	No Battery Output Voltage	Please attempt to reinsert and ensure charging connector is fully seated. Ensure use of a known good charger. Check for any debris that may be in charging port or plug and clear if present. If these actions for not correct the fault,discontinue use of the vehicle and contact after-sales service.
BC 21	Non-Load	Please attempt to reinsert and ensure charging connector is fully seated. Ensure use of a known good charger. Check for any debris that may be in charging port or plug and clear if present. If these actions for not correct the fault,discontinue use of the vehicle and contact after-sales service.
BC 22	CAN Communication Abnormal	Please attempt to reinsert and ensure charging connector is fully seated. Ensure use of a known good charger. Check for any debris that may be in charging port or plug and clear if present. If these actions for not correct the fault,discontinue use of the vehicle and contact after-sales service.

Fault Codes	Fault Contents	User's Operation Suggestions
BC 23	Internal Communication Abnormal	Please attempt to reinsert and ensure charging connector is fully seated. Ensure use of a known good charger. Check for any debris that may be in charging port or plug and clear if present. If these actions for not correct the fault,discontinue use of the vehicle and contact after-sales service.
BC 24	Charger CC1 Abnormal	Please attempt to reinsert and ensure charging connector is fully seated. Ensure use of a known good charger. Check for any debris that may be in charging port or plug and clear if present. If these actions for not correct the fault,discontinue use of the vehicle and contact after-sales service.

13.4 RIGHT WHEEL MOTOR CONTROLLER ERROR CODE

Fault Codes	Fault Contents	User's Operation Suggestions
TR 12	Right Wheel Motor Controller Over-current	Please restart vehicle and attempt to reduce load. Vehicle is disabled while fault is present.
TR 13	Right Wheel Motor Controller Current Sensor Abnormal	Please restart vehicle. If fault persists, contact after-sales service and discontinue use of the vehicle. Vehicle is disabled while fault is present.
TR 14	Right Wheel Motor Controller Pre-charge Failed	Please restart vehicle. If fault persists, contact after-sales service and discontinue use of the vehicle. Vehicle is disabled while fault is present.
TR 15	Right Wheel Motor Controller Severe Undertemp	Please ensure ambient temperature is above -40°C (-40°F) and restart vehicle. If fault persists, contact after-sales service and discontinue use of the vehicle. Vehicle is disabled while fault is present.
TR 16	Right Wheel Motor Controller Severe Overtemp	Please allow motor controller to cool and restart vehicle. Attempt to reduce load on right wheel. If these actions do not correct the fault, contact after-sales service and discontinue use of the vehicle. Vehicle is disabled while fault is present.
TR 19	Right Wheel Motor Controller Speed Limit Supervision	Right wheel speed is faster than vehicle max speed. Please restart vehicle and ensure vehicle is operating within standard speed range. If fault persists contact after-sales service and discontinue use of the vehicle. Vehicle is disabled while fault is present.
TR 1A	Right Wheel Motor Not Stopped	Please restart vehicle. If fault persists, contact after-sales service and discontinue use of the vehicle. Vehicle is disabled while fault is present.
TR 1D	Right Wheel Motor Controller Reset Rejected	Please restart vehicle. If fault persists, contact after-sales service and discontinue use of the vehicle. Vehicle is disabled while fault is present.
TR 1E	Right Wheel Motor Short	Please restart vehicle. If fault persists, contact after-sales service and discontinue use of the vehicle. Vehicle is disabled while fault is present.
TR 22	Right Wheel Motor Controller Overtemp Cutback	Vehicle has been put into a state of reduced performance while motor controller temperature high. Attempt to reduce vehicle load and allow controller to cool. Once temperature is back within standard range, restart the vehicle and normal operation will resume.
TR 25	Right Wheel Motor Controller Ext 5V Supply Failure	Please restart vehicle. If fault persists, contact after-sales service and discontinue use of the vehicle. Vehicle is disabled while fault is present.

Fault Codes	Fault Contents	User's Operation Suggestions
TR 26	Right Wheel Motor Controller Ext 12V Supply Failure	Please restart vehicle. If fault persists, contact after-sales service and discontinue use of the vehicle. Vehicle is disabled while fault is present.
TR 28	Right Wheel Motor Slight Overtemp	Vehicle has been put into a state of reduced performance while motor temperature high. Attempt to reduce vehicle load and allow motor to cool. Once temperature is back within standard range, restart the vehicle and normal operation will resume.
TR 29	Right Wheel Motor Temperature Sensor Abnormal	Please restart vehicle. If fault persists, contact after-sales service and discontinue use of the vehicle. Vehicle is disabled while fault is present.
TR 31	Main Contactor Coil Driver Short / Open	Please restart vehicle. If fault persists, contact after-sales service and discontinue use of the vehicle. Vehicle is disabled while fault is present.
TR 36	Right Wheel Motor Sin/Cos Encoder Abnormal	Please restart vehicle. If fault persists, contact after-sales service and discontinue use of the vehicle. Vehicle is disabled while fault is present.
TR 37	Right Wheel Motor Phase Open	Please restart vehicle. If fault persists, contact after-sales service and discontinue use of the vehicle. Vehicle is disabled while fault is present.
TR 38	Main Contactor Welded	Please restart vehicle. If fault persists, contact after-sales service and discontinue use of the vehicle. Vehicle is disabled while fault is present.
TR 39	Main Contactor Did Not Close	Please restart vehicle. If fault persists, contact after-sales service and discontinue use of the vehicle. Vehicle is disabled while fault is present.
TR 3A	Right Wheel Motor Controller Setup Needed	Please restart vehicle. If fault persists, contact after-sales service and discontinue use of the vehicle. Vehicle is disabled while fault is present.
TR 41	Right Throttle Wiper High	Please check throttle connection and restart vehicle. If fault persists, contact after-sales service and discontinue use of the vehicle. Vehicle is disabled while fault is present.
TR 42	Right Throttle Input Abnormal	Please check throttle connection and restart vehicle. If fault persists, contact after-sales service and discontinue use of the vehicle. Vehicle is disabled while fault is present.
TR 43	Right Pot2 Wiper High	Please check throttle connection and restart vehicle. If fault persists, contact after-sales service and discontinue use of the vehicle. Vehicle is disabled while fault is present.

Fault Codes	Fault Contents	User's Operation Suggestions
TR 46	Right Wheel Motor Controller NV Memory Failure	Please restart vehicle. If fault persists, contact after-sales service and discontinue use of the vehicle. Vehicle is disabled while fault is present.
TR 51	Display CAN Communication Abnormal	Please restart vehicle. If fault persists, contact after-sales service and discontinue use of the vehicle. Vehicle is disabled while fault is present.
TR 52	Left Wheel Motor Controller CAN Communication Abnormal	Please restart vehicle. If fault persists, contact after-sales service and discontinue use of the vehicle. Vehicle is disabled while fault is present.
TR 53	Vehicle Initial State Detection Abnormal	1. The right parking switch is not in parked position. Please return the right lever to the park position to enable operation. 2. The left parking switch is not in parked position. Please return the left lever to the park position to enable operation. 3. The PTO Switch (Blade Switch) is not in OFF position. Please ensure PTO switch is pressed into the off position. To enable operation. 4. Right side throttle lever is not in neutral position. Please ensure right throttle lever is in neutral position to enable operation. 5. Left side throttle lever is not in neutral position. Please ensure left throttle lever is in neutral position to enable operation.
TR 55	BMS CAN Communication Abnormal	Please restart vehicle. If fault persists, contact after-sales service and discontinue use of the vehicle. Vehicle is disabled while fault is present.
TR 56	Operator Presence Detection Abnormal	1. The operator is not in the correct operating position. Please ensure you are in the correct operating position to resume operation. 2. Right side throttle lever is not in neutral position. Please ensure right throttle lever is in returned to park position to resume operation. 3. Left side throttle lever is not in neutral position. Please ensure left throttle lever is in returned to park position to resume operation.
TR 58	Right Blade Motor Controller CAN Communication Abnormal	Please restart vehicle. If fault persists, contact after-sales service and discontinue use of the vehicle. Vehicle is disabled while fault is present.
TR 5A	Internal communication failure	Please restart vehicle. If fault persists, contact after-sales service and discontinue use of the vehicle. Vehicle is disabled while fault is present.
TR 5B	Right Parking Brake Manually Disengaged and Not Reset	Detected right parking brake is not engaged. Please re-engage parking brake.
TR 61	GPS Module CAN Communication Abnormal	Please restart vehicle. If fault persists, contact after-sales service and discontinue use of the vehicle. Vehicle is disabled while fault is present.

Fault Codes	Fault Contents	User's Operation Suggestions
TR 63	Left Blade Motor Controller CAN Communication Abnormal	Please restart vehicle. If fault persists, contact after-sales service and discontinue use of the vehicle. Vehicle is disabled while fault is present.
TR 64	Second Left Blade Motor Controller CAN Communication Abnormal	Please restart vehicle. If fault persists, contact after-sales service and discontinue use of the vehicle. Vehicle is disabled while fault is present.
TR 65	Middle Blade Motor Controller CAN Communication Abnormal	Please restart vehicle. If fault persists, contact after-sales service and discontinue use of the vehicle. Vehicle is disabled while fault is present.
TR 66	Second Right Blade Motor Controller CAN Communication Abnormal	Please restart vehicle. If fault persists, contact after-sales service and discontinue use of the vehicle. Vehicle is disabled while fault is present.
TR 67	Blade speed exceeds limit	Please restart vehicle. If fault persists, contact after-sales service and discontinue use of the vehicle. Vehicle is disabled while fault is present.
TR 73	Right Wheel Motor Stall Detected	Please restart vehicle and attempt to reduce load. If these actions for not correct the fault contact after-sales service. Vehicle is disabled while fault is present.
TR 77	Right Wheel Motor Controller Supervision Abnormal	Please restart vehicle. If fault persists, contact after-sales service and discontinue use of the vehicle. Vehicle is disabled while fault is present.
TR 79	Right Wheel Motor Controller Supervision Input Check	Please restart vehicle. If fault persists, contact after-sales service and discontinue use of the vehicle. Vehicle is disabled while fault is present.
TR 83	Right Wheel Motor Controller Internal Hardware	Please restart vehicle. If fault persists, contact after-sales service and discontinue use of the vehicle. Vehicle is disabled while fault is present.
TR 87	Right Wheel Motor Controller Motor Characterization Fault	Please restart vehicle. If fault persists, contact after-sales service and discontinue use of the vehicle. Vehicle is disabled while fault is present.
TR A1	Rear ETO Contactor Coil Driver Short/Open	Please restart vehicle. If fault persists, contact after-sales service and discontinue use of the vehicle. Vehicle is disabled while fault is present.
TR A2	Right Wheel Motor Controller EM Brake Driver Short/Open	Please restart vehicle. If fault persists, contact after-sales service and discontinue use of the vehicle. Vehicle is disabled while fault is present.
TR A3	Front ETO Contactor Coil Driver Short/Open	Please check front ETO port and ensure it is free of debris and restart vehicle. If fault persists, contact after-sales service and discontinue use of the vehicle. Vehicle is disabled while fault is present.

Fault Codes	Fault Contents	User's Operation Suggestions
TR A4	Auto power off Contactor Coil Driver Short/Open	Please restart vehicle. If fault persists, contact after-sales service and discontinue use of the vehicle. Vehicle is disabled while fault is present.
TR A9	Right Wheel Motor Controller Coil Supply	Please restart vehicle. If fault persists, contact after-sales service and discontinue use of the vehicle. Vehicle is disabled while fault is present.
TR B1	Right Wheel Motor Controller Analog 1 Out of Range	Please check throttle connection and restart vehicle. If fault persists, contact after-sales service and discontinue use of the vehicle. Vehicle is disabled while fault is present.
TR D2	Right Wheel Motor Controller Phase PWM Mismatch	Please restart vehicle. If fault persists, contact after-sales service and discontinue use of the vehicle. Vehicle is disabled while fault is present.

Note: Error Code TR 5B: This error may not indicate a real issue. Restart the machine to confirm whether the problem persists.

13.5 LEFT WHEEL MOTOR CONTROLLER ERROR CODE

Fault Codes	Fault Contents	User's Operation Suggestions
TL 12	Left Wheel Motor Controller Overcurrent	Please restart vehicle and attempt to reduce load. Vehicle is disabled while fault is present.
TL 13	Left Wheel Motor Controller Current Sensor Abnormal	Please restart vehicle. If fault persists, contact after-sales service and discontinue use of the vehicle. Vehicle is disabled while fault is present.
TL 14	Left Wheel Motor Controller Pre-charge Failed	Please restart vehicle. If fault persists, contact after-sales service and discontinue use of the vehicle. Vehicle is disabled while fault is present.
TL 15	Left Wheel Motor Controller Severe Undertemp	Please ensure ambient temperature is above -40°C (-40°F) and restart vehicle. If fault persists, contact after-sales service and discontinue use of the vehicle. Vehicle is disabled while fault is present.
TL 16	Left Wheel Motor Controller Severe Overtemp	Please allow motor controller to cool and restart vehicle. Attempt to reduce load on left wheel. If these actions do not correct the fault, contact after-sales service and discontinue use of the vehicle. Vehicle is disabled while fault is present.
TL 19	Left Wheel Motor Controller Speed Limit Supervision	Left wheel speed is faster than vehicle max speed. Please restart vehicle and ensure vehicle is operating within standard speed range. If fault persists contact, after-sales service and discontinue use of the vehicle. Vehicle is disabled while fault is present.
TL 1A	Left Wheel Motor Not Stopped	Please restart vehicle. If fault persists, contact after-sales service and discontinue use of the vehicle. Vehicle is disabled while fault is present.
TL 1D	Left Wheel Motor Controller Reset Rejected	Please restart vehicle. If fault persists, contact after-sales service and discontinue use of the vehicle. Vehicle is disabled while fault is present.
TL 1E	Left Wheel Motor Short	Please restart vehicle. If fault persists, contact after-sales service and discontinue use of the vehicle. Vehicle is disabled while fault is present.
TL 22	Left Wheel Motor Controller Overtemp Cutback	Vehicle has been put into a state of reduced performance while motor controller temperature high. Attempt to reduce vehicle load and allow controller to cool. Once temperature is back within standard range, restart the vehicle and normal operation will resume.
TL 25	Left Wheel Motor Controller Ext 5V Supply Failure	Please restart vehicle. If fault persists, contact after-sales service and discontinue use of the vehicle. Vehicle is disabled while fault is present.

Fault Codes	Fault Contents	User's Operation Suggestions
TL 26	Left Wheel Motor Controller Ext 12V Supply Failure	Please restart vehicle. If fault persists, contact after-sales service and discontinue use of the vehicle. Vehicle is disabled while fault is present.
TL 27	Left Wheel Motor Severe Overtemp	Please allow motor to cool and restart vehicle. Attempt to reduce load on left wheel. If these actions do not correct the fault, contact after-sales service and discontinue use of the vehicle. Vehicle is disabled while fault is present.
TL 28	Left Wheel Motor Slight Overtemp	Vehicle has been put into a state of reduced performance while motor temperature high. Attempt to reduce vehicle load and allow motor to cool. Once temperature is back within standard range, restart the vehicle and normal operation will resume.
TL 29	Left Wheel Motor Temperature Sensor Abnormal	Please restart vehicle. If fault persists, contact after-sales service. Vehicle is disabled while fault is present.
TL 31	Main Contactor Coil Driver Short / Open	Please restart vehicle. If fault persists, contact after-sales service and discontinue use of the vehicle. Vehicle is disabled while fault is present.
TL 36	Left Wheel Motor Sin/Cos Encoder Abnormal	Please restart vehicle. If fault persists, contact after-sales service and discontinue use of the vehicle. Vehicle is disabled while fault is present.
TL37	Left Wheel Motor Phase Open	Please restart vehicle. If fault persists, contact after-sales service and discontinue use of the vehicle. Vehicle is disabled while fault is present.
TL 38	Main Contactor Welded	Please restart vehicle. If fault persists, contact after-sales service and discontinue use of the vehicle. Vehicle is disabled while fault is present.
TL 39	Main Contactor Did Not Close	Please restart vehicle. If fault persists, contact after-sales service and discontinue use of the vehicle. Vehicle is disabled while fault is present.
TL 3A	Left Wheel Motor Controller Setup Needed	Please restart vehicle. If fault persists, contact after-sales service and discontinue use of the vehicle. Vehicle is disabled while fault is present.
TL 41	Left Throttle Wiper High	Please check throttle connection and restart vehicle. If fault persists, contact after-sales service and discontinue use of the vehicle. Vehicle is disabled while fault is present.
TL 42	Left Throttle Input Abnormal	Please check throttle connection and restart vehicle. If fault persists, contact after-sales service and discontinue use of the vehicle. Vehicle is disabled while fault is present.
TL 43	Left Pot2 Wiper High	Please check throttle connection and restart vehicle. If fault persists, contact after-sales service and discontinue use of the vehicle. Vehicle is disabled while fault is present.

Fault Codes	Fault Contents	User's Operation Suggestions
		ue use of the vehicle. Vehicle is disabled while fault is present.
TL 46	Left Wheel Motor Controller NV Memory Failure	Please restart vehicle. If fault persists, contact after-sales service and discontinue use of the vehicle. Vehicle is disabled while fault is present.
TL 52	Right Wheel Motor Controller CAN Communication Abnormal	Please restart vehicle. If fault persists, contact after-sales service and discontinue use of the vehicle. Vehicle is disabled while fault is present.
TL 5A	Internal communication failure	Please restart vehicle. If fault persists, contact after-sales service and discontinue use of the vehicle. Vehicle is disabled while fault is present.
TL 5B	Left Parking Brake Manually Disengaged and Not Reset	Detected left parking brake is not engaged. Please re-engage parking brake.
TL 73	Left Wheel Motor Stall Detected	Please restart vehicle and attempt to reduce load. If these actions for not correct the fault contact after-sales service. Vehicle is disabled while fault is present.
TL 77	Left Wheel Motor Controller Supervision Abnormal	Please restart vehicle. If fault persists, contact after-sales service and discontinue use of the vehicle. Vehicle is disabled while fault is present.
TL 79	Left Wheel Motor Controller Supervision Input Check	Please restart vehicle. If fault persists, contact after-sales service and discontinue use of the vehicle. Vehicle is disabled while fault is present.
TL 83	Left Wheel Motor Controller Internal Hardware	Please restart vehicle. If fault persists, contact after-sales service and discontinue use of the vehicle. Vehicle is disabled while fault is present.
TL 87	Left Wheel Motor Controller Motor Characterization Fault	Please restart vehicle. If fault persists, contact after-sales service and discontinue use of the vehicle. Vehicle is disabled while fault is present.
TL A2	Left Wheel Motor Controller EM Brake Driver Coil Short/Open	Please restart vehicle. If fault persists, contact after-sales service and discontinue use of the vehicle. Vehicle is disabled while fault is present.
TL A3	Deck Linear Actuator Driver Coil Up Short/Open	Please restart vehicle. If fault persists, contact after-sales service and discontinue use of the vehicle. Vehicle is disabled while fault is present.
TL A4	Deck Linear Actuator Driver Coil Down Short/Open	Please restart vehicle. If fault persists, contact after-sales service and discontinue use of the vehicle. Vehicle is disabled while fault is present.
TL A9	Left Wheel Motor Controller Coil Supply	Please restart vehicle. If fault persists, contact after-sales service and discontinue use of the vehicle. Vehicle is disabled while fault is present.

Fault Codes	Fault Contents	User's Operation Suggestions
TL B1	Left Wheel Motor Controller Analog 1 Out of Range	Please check throttle connection and restart vehicle. If fault persists, contact after-sales service and discontinue use of the vehicle. Vehicle is disabled while fault is present.
TL D2	Left Wheel Motor Controller Phase PWM Mismatch	Please restart vehicle. If fault persists, contact after-sales service and discontinue use of the vehicle. Vehicle is disabled while fault is present.

Note: Error Code TL 5B: This error may not indicate a real issue. Restart the machine to confirm whether the problem persists.

13.6 LEFT BLADE MOTOR CONTROLLER ERROR CODE

Fault Codes	Fault Contents	User's Operation Suggestions
ML 11	Left Blade Motor Controller Hardware Overvoltage or Overcurrent	Please reduce the blade load and restart the vehicle. Check that blades are free of debris. Blades are disabled while fault present.
ML 12	Left Blade Motor Controller Overcurrent	Please reduce the blade load and restart PTO. Check that blades are free of debris. Blades are disabled while fault present.
ML 13	Left Blade Motor Controller Overvoltage	Please restart PTO to clear fault. Blades are disabled while fault present.
ML 14	Left Blade Motor Controller Undervoltage	Please restart PTO to clear fault. Blades are disabled while fault present.
ML 15	Current Parameter Mismatch Fault	Please restart vehicle. If fault persists, contact after-sales service and check whether the program is correct. Blades are disabled while fault is present.
ML 16	Left Blade Motor Phase Open	Please restart vehicle. If fault persists, contact after-sales service and discontinue use of the vehicle. Blades are disabled while fault is present.
ML 17	Left Blade Motor Controller Severe Overtemp	Please reduce the blade load. Allow controller to cool and restart vehicle. Check that blades are free of debris. Blades are disabled until unit restart.
ML 18	Left Blade Motor Controller EEPROM Abnormal	Please restart vehicle. If fault persists, contact after-sales service and discontinue use of the vehicle. Blades are disabled while fault is present.
ML 21	Left Blade Motor Stall Detected	Please reduce the blade load and restart the PTO. Check that blades are free of debris. Blades are disabled while fault present.
ML 22	Left Blade Motor System Start Failure	Please reduce the blade load and restart the PTO. Check that blades are free of debris. Blades are disabled while fault present.
ML 23	Left Blade Motor Controller Precharge Failed	Please restart vehicle. If fault persists, contact after-sales service and discontinue use of the vehicle. Blades are disabled while fault is present.
ML 24	CAN Communication with Right Wheel Motor Controller Abnormal	Please restart vehicle. If fault persists, contact after-sales service and discontinue use of the vehicle. Blades are disabled while fault is present.
ML 26	Left Blade Motor Controller MOSFET Abnormal	Please restart vehicle. If fault persists, contact after-sales service and discontinue use of the vehicle. Blades are disabled while fault is present.

Fault Codes	Fault Contents	User's Operation Suggestions
ML 27	Left Blade Motor Controller Temperature Sensor Abnormal	Please restart vehicle. If fault persists, contact after-sales service and discontinue use of the vehicle. Blades are disabled while fault is present.
ML 28	Left Blade Motor Controller Self-Check Abnormal	Please restart vehicle. If fault persists, contact after-sales service and discontinue use of the vehicle. Blades are disabled while fault is present.

13.7 MIDDLE BLADE MOTOR CONTROLLER ERROR CODE

Fault Codes	Fault Contents	User's Operation Suggestions
MM 11	Middle Blade Motor Controller Hardware Overvoltage or Overcurrent	Please reduce the blade load and restart the vehicle. Check that blades are free of debris. Blades are disabled while fault present.
MM 12	Middle Blade Motor Controller Overcurrent	Please reduce the blade load and restart PTO. Check that blades are free of debris. Blades are disabled while fault present.
MM 13	Middle Blade Motor Controller Overvoltage	Please restart PTO to clear fault. Blades are disabled while fault present.
MM 14	Middle Blade Motor Controller Undervoltage	Please restart PTO to clear fault. Blades are disabled while fault present.
MM 16	Middle Blade Motor Phase Open	Please restart vehicle. If fault persists, contact after-sales service and discontinue use of the vehicle. Blades are disabled while fault is present.
MM 17	Middle Blade Motor Controller Severe Overtemp	Please reduce the blade load. Allow controller to cool and restart vehicle. Check that blades are free of debris. Blades are disabled until unit restart.
MM 18	Middle Blade Motor Controller EEPROM Abnormal	Please restart vehicle. If fault persists, contact after-sales service and discontinue use of the vehicle. Blades are disabled while fault is present.
MM 21	Middle Blade Motor Stall Detected	Please reduce the blade load and restart the PTO. Check that blades are free of debris. Blades are disabled while fault present.
MM 22	Middle Blade Motor System Start Failure	Please reduce the blade load and restart the PTO. Check that blades are free of debris. Blades are disabled while fault present.
MM 23	Middle Blade Motor Controller Precharge Failed	Please restart vehicle. If fault persists, contact after-sales service and discontinue use of the vehicle. Blades are disabled while fault is present.
MM 24	CAN Communication with Right Wheel Motor Controller Abnormal	Please restart vehicle. If fault persists, contact after-sales service and discontinue use of the vehicle. Blades are disabled while fault is present.
MM 26	Middle Blade Motor Controller MOSFET Abnormal	Please restart vehicle. If fault persists, contact after-sales service and discontinue use of the vehicle. Blades are disabled while fault is present.
MM 27	Middle Blade Motor Controller Temperature Sensor Abnormal	Please restart vehicle. If fault persists, contact after-sales service and discontinue use of the vehicle. Blades are disabled while fault is present.

Fault Codes	Fault Contents	User's Operation Suggestions
MM 28	Middle Blade Motor Controller Self-Check Abnormal	Please restart vehicle. If fault persists, contact after-sales service and discontinue use of the vehicle. Blades are disabled while fault is present.

13.8 RIGHT BLADE MOTOR CONTROLLER ERROR CODE

Fault Codes	Fault Contents	User's Operation Suggestions
MR 11	Right Blade Motor Controller Hardware Overvoltage or Overcurrent	Please reduce the blade load and restart the vehicle. Check that blades are free of debris. Blades are disabled while fault present.
MR 12	Right Blade Motor Controller Overcurrent	Please reduce the blade load and restart PTO. Check that blades are free of debris. Blades are disabled while fault present.
MR 13	Right Blade Motor Controller Overvoltage	Please restart PTO to clear fault. Blades are disabled while fault present.
MR 14	Right Blade Motor Controller Undervoltage	Please restart PTO to clear fault. Blades are disabled while fault present.
MR 16	Right Blade Motor Phase Open	Please restart vehicle. If fault persists, contact after-sales service and discontinue use of the vehicle. Blades are disabled while fault is present.
MR 17	Right Blade Motor Controller Severe Overtemp	Please reduce the blade load. Allow controller to cool and restart vehicle. Check that blades are free of debris. Blades are disabled until unit restart.
MR 18	Right Blade Motor Controller EEPROM Abnormal	Please restart vehicle. If fault persists, contact after-sales service and discontinue use of the vehicle. Blades are disabled while fault is present.
MR 21	Right Blade Motor Stall Detected	Please reduce the blade load and restart the PTO. Check that blades are free of debris. Blades are disabled while fault present.
MR 22	Right Blade Motor System Start Failure	Please reduce the blade load and restart the PTO. Check that blades are free of debris. Blades are disabled while fault present.
MR 23	Right Blade Motor Controller Precharge Failed	Please restart vehicle. If fault persists, contact after-sales service and discontinue use of the vehicle. Blades are disabled while fault is present.
MR 24	CAN Communication with Right Wheel Motor Controller Abnormal	Please restart vehicle. If fault persists, contact after-sales service and discontinue use of the vehicle. Blades are disabled while fault is present.
MR 26	Right Blade Motor Controller MOSFET Abnormal	Please restart vehicle. If fault persists, contact after-sales service and discontinue use of the vehicle. Blades are disabled while fault is present.
MR 27	Right Blade Motor Controller Temperature Sensor Abnormal	Please restart vehicle. If fault persists, contact after-sales service and discontinue use of the vehicle. Blades are disabled while fault is present.

Fault Codes	Fault Contents	User's Operation Suggestions
MR 28	Right Blade Motor Controller Self-Check Abnormal	Please restart vehicle. If fault persists, contact after-sales service and discontinue use of the vehicle. Blades are disabled while fault is present.

13.9 DECK LINEAR ACTUATOR ERROR CODE

Fault Codes	Fault Contents	User's Operation Suggestions
LA 11	Deck Linear Actuator Hall Error	Please restart vehicle. If fault persists, contact after-sales service.
LA 12	Deck Linear Actuator Overvoltage	Please restart vehicle. If fault persists, contact after-sales service.
LA 13	Deck Linear Actuator Undervoltage	Please check if the connectors of the DC-DC unit are well connected. Please restart vehicle. If fault persists, contact after-sales service.
LA 14	Deck Linear Actuator CAN Timeout Error	Please check if the connectors of the DC-DC unit are well connected. Please restart vehicle. If fault persists, contact after-sales service.
LA 15	Deck Linear Actuator ESS Error	Please restart vehicle. If fault persists, contact after-sales service.
LA 16	Deck Linear Actuator Power On Block State	Please restart vehicle. If fault persists, contact after-sales service.
LA 17	Deck Linear Actuator Temperature Error	Please restart vehicle. If fault persists, contact after-sales service.
LA 18	Deck Linear Actuator Heart Beat Error (internal)	Please restart vehicle. If fault persists, contact after-sales service.
LA 19	Deck Linear Actuator SMPS (internal)	Please restart vehicle. If fault persists, contact after-sales service.

greenworks[®]

COMMERCIAL

www.greenworksaustralia.com



P0806430-00