

greenworks®

CRZ426

EN

ZERO-TURN MOWER

OPERATOR MANUAL

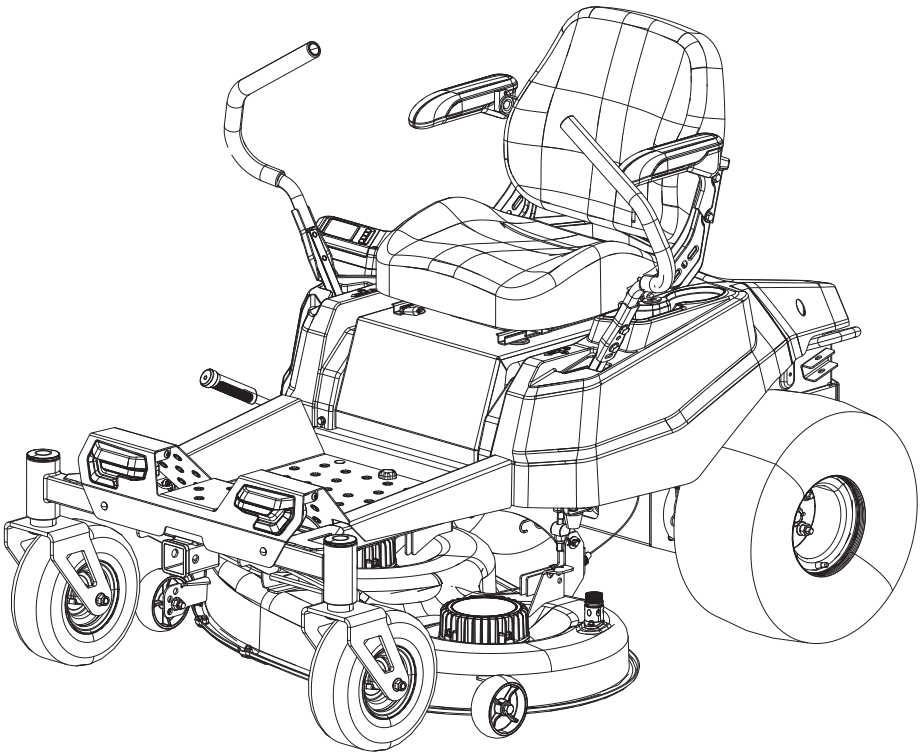

E8038

Greenworks Australia
A Division Jak Max P/L
380 Foley's Road Derrimut
Victoria, Australia 3026
www.greenworksaustralia.com

1	Introduction.....	2	7.4	Neutral bypass lever.....	19
1.1	Product description.....	2	8	Clean and storage.....	20
1.2	Intended use.....	2	8.1	Clean the product.....	20
1.3	Symbols on the product.....	2	8.2	Clean the mower deck.....	20
2	Safety.....	2	8.3	Store the product.....	20
2.1	Safety definitions.....	2	9	Maintenance.....	21
2.2	General safety warnings.....	3	9.1	Maintenance safety.....	21
2.3	Ride-on mower safety warnings.....	4	9.2	Battery maintenance.....	21
2.4	Read all instructions.....	5	9.3	Recommended maintenance schedules.....	22
3	Assembly.....	8	9.4	Check tire pressure.....	22
3.1	Install the seat.....	8	9.5	Torque values.....	22
3.2	Install the steering control lever.....	9	9.6	Lubrication.....	23
4	Features and controls.....	9	9.7	Side discharge to mulching(Optional)....	23
4.1	Product controls.....	9	9.8	Service the mower blades.....	24
5	Electrical system.....	13	10	Troubleshooting.....	27
5.1	Electrical system safety.....	13	11	Technical data.....	29
5.2	Electrical system information.....	13	12	Warranty.....	29
6	Operation.....	13	13	Errors.....	29
6.1	Charging.....	13	13.1	Right wheel motor controller error codes.....	30
6.2	App operation tips.....	15	13.2	Left wheel motor controller error codes.....	34
6.3	Start the product.....	15	13.3	Right blade motor controller error codes.....	37
6.4	Zero-turn mower driving practice.....	16	13.4	Left blade motor controller error codes..	39
6.5	Stop the product.....	17	13.5	Power management unit (in the battery compartment) error codes.....	41
6.6	Mowing.....	17	13.6	Display screen error codes.....	42
6.7	Mowing patterns.....	18			
6.8	Mowing recommendations.....	18			
7	Transportation.....	19			
7.1	Transport the mower.....	19			
7.2	Transport the lithium-ion battery.....	19			
7.3	Move the mower manually.....	19			

1 INTRODUCTION

1.1 PRODUCT DESCRIPTION











This product is a battery-operated zero-turn mower with electric motors.









We are committed to continuously improving our products and reserve the right to modify the design and appearance without prior notice.

1.2 INTENDED USE

The product is designed for efficiently cutting and maintaining grass on residential lawns and outdoor spaces. It is not designed for any other purpose.

1.3 SYMBOLS ON THE PRODUCT

Symbol	Explanation
IPX4	Protection from splashing water.
	Type or a characteristic of current
	Indicates a potential personal injury hazard.
	To reduce the risk of injury, user must read and understand operator's manual before using this product.
	Wear ear protection.
	Always wear safety goggles or safety glasses with side shields and a full face shield when operating this product.
	Protective Ground. IEC 60417-5019(2006-08).
	Professional training is required before operating the product.
	Do not mow when children or others are around.
	Do not open or remove safety shields while the product is running.
 	To reduce the risk of injury, keep hands and feet away from rotating parts. Do not operate unless discharge cover or grass bag is in its proper place. If damaged, replace immediately.

Symbol	Explanation
	Do not tow this product, it may cause damage to the drive system.
	Never carry children or anyone, even when the blades are off.
	Always look down and behind you when maneuvering in reverse or turning around. Make sure children, bystanders, and pets are clear of the area.
	Use extra caution on slopes. Do not mow slopes greater than 15 degrees. Do not use on slopes near open water.
	Remove objects that can be thrown by the blade in any direction. Wear safety glasses.
	Keep all bystanders at least 30m (100ft.) away.
	Do not step.
	CAUTION --- Do not stare at operating lamp.
	Pull the neutral bypass lever outward to release the drive brake. Never unlock the neutral bypass lever on slopes. It can cause a loss of control.

2 SAFETY

2.1 SAFETY DEFINITIONS

Warnings, cautions, and notes are used to point out especially important parts of the manual.

▲ WARNING

THERE IS A RISK OF INJURY OR DEATH FOR THE OPERATOR OR BYSTANDERS, IF THE INSTRUCTIONS IN THE MANUAL ARE NOT OBEYED.

▲ CAUTION

THERE IS A RISK OF DAMAGE TO THE PRODUCT, OTHER MATERIALS, OR THE ADJACENT AREA, IF THE INSTRUCTIONS IN THE MANUAL ARE NOT OBEYED.

Note: Used to give more information that is necessary in a given situation.

2.2 GENERAL SAFETY WARNINGS

▲ WARNING

Read all safety warnings, instructions, illustrations and specifications provided with this product.

Failure to follow all instructions listed below may result in electric shock, fire and/or serious injury.

Save all warnings and instructions for future reference.

The term "product" in the warnings refers to your mains-operated (corded) product or BATTERY-operated (cordless) product.

2.2.1 WORK AREA SAFETY

- **Keep work area clean and well lit.** *Cluttered or dark areas invite accidents.*
- **Do not operate the product in explosive atmospheres, such as in the presence of flammable liquids, gases or dust.** *The product creates sparks which may ignite the dust or fumes.*
- **Keep children and bystanders away while operating the product.** *Distractions can cause you to lose control.*

2.2.2 ELECTRICAL SAFETY

- **Product plugs must match the outlet. Never modify the plug in any way. Do not use any adapter plugs with earthed (grounded) product.** *Unmodified plugs and matching outlets will reduce risk of electric shock.*
- **Avoid body contact with earthed or grounded surfaces, such as pipes, radiators, ranges and refrigerators.** *There is an increased risk of electric shock if your body is earthed or grounded.*
- **Do not expose the product to rain or wet conditions.** *Water entering a product will increase the risk of electric shock.*
- **Do not abuse the cord. Never use the cord for carrying, pulling or unplugging the product. Keep cord away from heat, oil, sharp edges or moving parts.** *Damaged or entangled cords increase the risk of electric shock.*
- **When operating the product outdoors, use an extension cord suitable for outdoor use.** *Use of a cord suitable for outdoor use reduces the risk of electric shock.*
- **If operating the product in a damp location is unavoidable, use a Residual Current Device (RCD) protected supply.** *Use of an RCD reduces the risk of electric shock.*
- **Do not clean the product with water from a hose or a pressure washer.** *Water entering a product will increase the risk of electric shock.*
- **Do not operate the product in rain.** *Water entering a product will increase the risk of electric shock.*

2.2.3 PERSONAL SAFETY

- **Stay alert, watch what you are doing and use common sense when operating the product. Do not use the product while you are tired or under the influence of drugs, alcohol or medication.** *A moment of inattention while operating the product may result in serious personal injury.*
- **Use personal protective equipment. Always wear eye protection.** *Protective equipment such as a dust mask, non-skid safety shoes, hard hat, or hearing protection used for appropriate conditions will reduce personal injuries.*
- **Prevent unintentional starting. Ensure the switch is in the off-position before connecting to power source and/or Battery pack, picking up or carrying the product.** *Carrying power tools with your finger on the switch or energizing power tools that have the switch on invites accidents.*
- **Remove any adjusting key or wrench before turning the product on.** *A wrench or a key left attached to a rotating part of the product may result in personal injury.*
- **Do not overreach. Keep proper footing and balance at all times.** *This enables better control of the product in unexpected situations.*
- **Dress properly. Do not wear loose clothing or jewelry. Keep your hair, clothing away from moving parts.** *Loose clothes, jewelry or long hair can be caught in moving parts.*
- **If devices are provided for the connection of dust extraction and collection facilities, ensure these are connected and properly used.** *Use of dust collection can reduce dust-related hazards.*
- **Do not let familiarity gained from frequent use of tools allow you to become complacent and ignore tool safety principles.** *A careless action can cause severe injury within a fraction of a second.*

2.2.4 PRODUCT USE AND CARE

- **Do not force the product. Use the correct product for your application.** *The correct product will do the job better and safer at the rate for which it was designed.*
- **Do not use the product if the switch does not turn it on and off.** *Any product that cannot be controlled with the switch is dangerous and must be repaired.*
- **Disconnect the plug from the power source and/or remove the BATTERY pack, if detachable, from the product before making any adjustments, changing accessories, or storing the product.** *Such preventive safety measures reduce the risk of starting the product accidentally.*
- **Store an idle product out of the reach of children and do not allow persons unfamiliar with the product or these instructions to operate the**

product. *A product is dangerous in the hands of untrained users.*

- **Maintain the product and accessories.** Check for misalignment or binding of moving parts, breakage of parts and any other condition that may affect the operation of the product. If damaged, have the product repaired before use. *Many accidents are caused by poorly maintained product.*
- **Keep cutting tools sharp and clean.** *Properly maintained cutting tools with sharp cutting edges are less likely to bind and are easier to control.*
- **Use the product, accessories and tool bits etc. in accordance with these instructions, taking into account the working conditions and the work to be performed.** *Use of the product for operations different from those intended could result in a hazardous situation.*
- **Keep handles and grasping surfaces dry, clean and free from oil and grease.** *Slippery handles and grasping surfaces do not allow for safe handling and control of the product in unexpected situations.*
- **Remove the key or disable the product when leaving the product unattended.** *The product is dangerous to untrained users.*

2.2.5 BATTERY TOOL USE AND CARE

- **Recharge only with the charger specified by the manufacturer.** *A charger that is suitable for one type of battery pack may create a risk of fire when used with another battery pack.*
- **Use the product only with specifically designated battery packs.** *Use of any other battery packs may create a risk of injury and fire.*
- **When battery pack is not in use, keep it away from other metal objects, like paper clips, coins, keys, nails, screws or other small metal objects, that can make a connection from one terminal to another.** *Shorting the battery terminals together may cause burns or fire.*
- **Under abusive conditions, liquid may be ejected from the battery; avoid contact.** *If contact accidentally occurs, flush with water. If liquid contacts eyes, additionally seek medical help. Liquid ejected from the battery may cause irritation or burns.*
- **Do not use a battery pack or product that is damaged or modified.** *Damaged or modified batteries may exhibit unpredictable behavior resulting in fire, explosion or risk of injury.*
- **Do not expose a battery pack or product to fire or excessive temperature.** *Exposure to fire or temperature above 265°F (130°C) may cause explosion.*
- **Follow all charging instructions and do not charge the battery pack or product outside the temperature range specified in the instructions.** *Charging improperly or at temperatures outside*

the specified range may damage the battery and increase the risk of fire.

2.2.6 SERVICE

- **Have your product serviced by a qualified repair person using only identical replacement parts.** *This will ensure that the safety of the product is maintained.*
- **Never service damaged battery packs.** *Service of battery packs should only be performed by the manufacturer or authorized service providers.*

2.3 RIDE-ON MOWER SAFETY WARNINGS

- **Do not use the mower in bad weather conditions, especially when there is a risk of lightning.** *This decreases the risk of being struck by lightning.*
- **Thoroughly inspect the area for wildlife where the mower is to be used.** *Wildlife may be injured by the mower during operation.*
- **Thoroughly inspect the area where the mower is to be used and remove all stones, sticks, wires, bones, and other foreign objects.** *Thrown objects can cause personal injury.*
- **Before using the mower, always visually inspect to see that the blade and the blade assembly are not worn or damaged.** *Worn or damaged parts increase the risk of injury.*
- **Keep guards in place. Guards must be in working order and be properly mounted.** *A guard that is loose, damaged, or is not functioning correctly may result in personal injury.*
- **Keep all cooling air inlets clear of debris.** *Blocked air inlets and debris may result in overheating or risk of fire.*
- **While operating the mower, always wear non-slip and protective footwear. Do not operate the mower when barefoot or wearing open sandals.** *This reduces the chance of injury to the feet from contact with the moving blade.*
- **While operating the mower, always wear long pants.** *Exposed skin increases the likelihood of injury from thrown objects.*
- **Do not operate the mower on slopes greater than 15 degrees.** *This reduces the risk of loss of control, slipping and falling which may result in personal injury.*
- **When working on slopes, always be sure of your footing.** *This reduces the risk of loss of control, slipping and falling which may result in personal injury.*
- **Do not mow from side-to-side when operating mowers on unlevel or sloped ground. Always mow slopes in the up-and-down direction.** *This reduces the risk of loss of control, slipping and falling which may result in personal injury.*

- **Do not touch blades and other hazardous moving parts while they are still in motion.** *This reduces the risk of injury from moving parts.*
- **When clearing jammed material or cleaning the mower, make sure all power switches are off and remove (or activate) the disabling device.** *Unexpected operation of the mower may result in serious personal injury.*
- Use extreme caution when reversing or pulling the lawnmower towards you. Always be aware of your surroundings.
- The user and technician **SHALL** carefully review **ALL** applicable original equipment manufacturer (OEM) safety-related repair manual procedures, training, and precautions before use, maintenance and service.

Note: *The user and technician should consult a medical professional if they have or are wearing:*

- An implanted defibrillator.
- A cardiac pacemaker.
- An internal analgesic medication pump.
- An insulin pump.
- Hearing aids.
- Other medical devices.

2.4 READ ALL INSTRUCTIONS

▲ DANGER

This mower was built to be operated according to the rules for safe operation that are contained in this manual. As with any type of power equipment, carelessness or error on the part of the operator can result in serious injury. This mower is capable of amputating body parts and throwing objects. Failure to observe the following safety rules could result in serious injury or death.

▲ WARNING

Basic safety precautions should always be followed when using lawnmowers in order to reduce the risk of fire, electric shock, and personal injury.

▲ WARNING

Use of this mower should be restricted to individuals who have read and understand and will follow the warnings and instructions that are printed in this manual and on the mower.

▲ WARNING

- Carefully read all instructions on the mower and in the manual before attempting to assemble and operate the mower.
- For safe operation, read, understand, and follow all instructions in this manual.
- Become familiar with all controls and their proper operation. Know how to stop the mower and how to disengage the power in an emergency.
- Keep this manual in a safe place for reference and consult it regularly.

2.4.1 GENERAL SAFETY

- Do not use battery-operated ride-on mower in rain.
- Only allow responsible, capable adults who are familiar with the instructions to operate this product.
- Safe operation requires your full attention and capabilities.
- Always look where you are going and be aware of your surroundings.
- Listen to the product and be aware of any change.
- Feel the product and its responses from both your inputs and the environment.
- Remain focused on your task.
- Always wear proper eye protection that complies with the latest safety standards in order to reduce the risk of eye injury while operating or performing any adjustment or repair. See ANSI Z87.1.
- Do not operate product unless discharge guard or other safety devices are in place and working.
- Always wear a face mask or a dust mask while operating the mower in a dusty environment.
- Always dress properly. The wearing of protective gloves and safety footwear is recommended.
- Never operate the product while using a mobile phone or any other electronic device. Operating while distracted can increase the risk of serious personal injury to the operator and bystanders.
- Do not operate the equipment while wearing sandals, tennis shoes, sneakers, shorts or any type of loose-fitting clothing. Wear safety shoes, hard hats, long pants, protective eyewear and hearing protection during operation to reduce the risk of personal injury. Avoid loose-fitting clothing, jewelry and any other apparel that could be caught on moving parts. Secure hair above shoulder level before starting work.
- Never carry passengers and keep bystanders away.
- Follow the manufacturer's recommendation for wheel weights or counterweights.

2.4.2 PREPARATION BEFORE OPERATING

- Clear the operating area of any objects which could be thrown by or interfere with operation of the product.

- Keep the area of operation clear of all bystanders, particularly small children. Stop the product and attachment(s) if anyone enters the area.
- Do not operate the product without the entire grass catcher, discharge chute, or other safety devices in place and functioning properly. Check frequently for signs of wear or deterioration and replace as needed.
- Wear appropriate personal protective equipment such as safety glasses, hearing protection, and footwear.
- Do not carry passengers anywhere on the product. Keep pets and bystanders out of the mowing area during operation.
- Do not leave a running product unattended. Always park on level ground, disengage the attachment, set parking brake, and stop product.
- Do not put hands or feet near rotating parts or under the cutting deck. Contact with the blade can amputate hands and feet.
- If the mower starts to vibrate excessively, stop the motor and check for the cause immediately. Excessive vibration is generally a sign the mower is not functioning properly.
- Stop the motor and wait until the blade comes to a complete stop before unclogging the chute. The cutting blade will continue to rotate for a few seconds after the motor is shut off. Do not place any part of your body in the blade area until you are sure that the blade has stopped rotating.

2.4.3 OPERATING

- Never operate a poorly maintained product. Repair or replace any damaged components before restarting and operating the lawnmower.
- Always keep safety shields and covers in place.
- Follow daily and weekly checklists, making sure electrical connections are secured and bolts are tightened.
- Never operate mower without a proper trail shield, discharge cover, switch control, or other safety device in place and in working order. Do not operate the mower with damaged safety devices; doing so can result in injury.
- Minimize exposure to water. Do not drive into water. Do not leave in rain. Do not clean with pressurized water or hose.
- Always drive with both hands. Do not drive with just one hand.
- Only operate the product in daylight or good artificial light.
- Avoid holes, ruts, bumps, rocks, or other hidden hazards. Uneven terrain could overturn the product, or cause operator to lose their balance or footing.
- Do not put hands or feet near rotating parts or under the product. Keep clear of the discharge opening at all times.
- Do not direct discharge material toward anyone. Avoid discharging material against a wall or obstruction. Material may ricochet back toward the operator. Stop the blade(s) when crossing gravel surfaces.
- Never attempt high-speed maneuvering, especially in crowded, congested areas or on slopes.
- Slow down before turning.
- In order to avoid contact with the blade or injury caused by a thrown object, stay in the operating zone behind the handles, and keep children and bystanders at least 100ft (30m) away from the mower while it is in operation. Stop the motor immediately if someone enters the mowing area.

- Do not leave a running product unattended. Always park on level ground, disengage the attachment, set parking brake, and stop product.
- Do not put hands or feet near rotating parts or under the cutting deck. Contact with the blade can amputate hands and feet.
- If the mower starts to vibrate excessively, stop the motor and check for the cause immediately. Excessive vibration is generally a sign the mower is not functioning properly.
- Stop the motor and wait until the blade comes to a complete stop before unclogging the chute. The cutting blade will continue to rotate for a few seconds after the motor is shut off. Do not place any part of your body in the blade area until you are sure that the blade has stopped rotating.
- If lawnmower strikes a foreign object, stop the product, rotate the ignition switch to OFF position, then, if it is safe, inspect for damage.
- Don't force the lawnmower.
- Do not use the mower for any job except that for which it is intended.
- Do not mow in reverse unless absolutely necessary. Always look down, behind and to the side before changing directions or backing up. A careless action can cause inflict death or severe injury within a fraction of a second.

2.4.4 CHILD SAFETY

Tragic accidents can occur if the operator is not aware of the presence of children. Children are often attracted to the product and the mowing activity. Never assume that children will remain where you last saw them.

- Never leave product unattended with key in switch, especially with children present.
- Keep children out of the mowing area and under the watchful care of a responsible adult other than the operator.
- Do not allow children under the age of 14 to operate this mower. Children who are 14 years of age and older must read and understand the operating instructions and safety rules in this manual, and must be trained and supervised by a parent.
- Always disengage deck blade switch and turn key to "OFF" position and remove key.
- Stay alert, and turn the mower off if a child or any other person enters the mowing area.
- Use extreme care when approaching blind corners, doorways, shrubs, trees, or other objects that may obscure your view of a child who may run into the path of the mower.
- Before and while backing, look behind and down for small children.
- Never carry children on the mower with you, even with the blade(s) shut off. They may fall off and be seriously injured or interfere with safe product operation. Children who have been given rides in

the past may suddenly appear in the mowing area for another ride and be run over or backed over by the product.

2.4.5 USE A RAMP

- When loading or unloading the product from a trailer, always use full width ramps that extend beyond the width of the product.
- This provides a surface for the mower frame to contact if the unit starts to tip backwards. It also reduces the risk of a wheel going off and the product tipping over.
- Do not exceed a 15-degree angle between the ramp and the ground or between the ramp and the trailer or truck.
- Become familiar with the mower's controls and confident in its smooth operation before attempting to drive it up or down a ramp.
- Use slow drive mode and drive carefully.
- Avoid any sudden movement of the controls and use only slow, even acceleration.

2.4.6 TOWING

- Tow only with a product that has a hitch designed for towing. Do not attach towed equipment except at the hitch point.
- Follow the manufacturer's recommendation for weight limits for towed equipment and towing on slopes. See **Rear Trailer Hitch** section. (Reference 4.1.7)
- Never allow children or others in or on towed equipment.
- On slopes, the weight of the towed equipment may cause loss of traction and loss of control.
- Travel slowly and allow extra distance to stop.

2.4.7 BATTERY AND CHARGER

- Prevent unintentional starting. Ensure the switch is in the off-position before connecting to battery, picking up or carrying the appliance. Carrying the appliance with your finger on the switch or energizing appliance that have the switch on invites accidents.
- Disconnect the battery from the appliance before making any adjustments, changing accessories, or storing appliance. Such preventive safety measures reduce the risk of starting the appliance accidentally.
- Recharge only with the charger specified by the manufacturer. A charger that is suitable for one type of battery may create a risk of fire when used with another battery.
- Use appliances only with specifically designated batteries. Use of any other batteries may create a risk of injury and fire.
- When battery is not in use, keep it away from other metal objects, like paper clips, coins, keys, nails, screws or other small metal objects, that can make

a connection from one terminal to another. Shorting the battery terminals together may cause burns or a fire.

- Under abusive conditions, liquid may be ejected from the battery; avoid contact. If contact accidentally occurs, flush with water. If liquid contacts eyes, additionally seek medical help. Liquid ejected from the battery may cause irritation or burns.
- Do not use a battery or appliance that is damaged or modified. Damaged or modified batteries may exhibit unpredictable behavior resulting in fire, explosion or risk of injury.
- Do not expose a battery or appliance to fire or excessive temperature. Exposure to fire or temperature above 265°F (130 °C) may cause explosion.
- Follow all charging instructions and do not charge the battery or appliance outside of the temperature range specified in the instructions. Charging improperly or at temperatures outside of the specified range may damage the battery and increase the risk of fire.
- Have servicing performed by a qualified repair person using only identical replacement parts. This will ensure that the safety of the product is maintained.
- Do not modify or attempt to repair the appliance or the battery (as applicable) except as indicated in the instructions for use and care.

2.4.8 SLOPE OPERATION

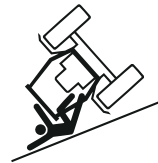

Slopes are a major factor related to accidents. Operation on slopes requires extra caution. To reduce the risk of injury, never operate the product under any condition where you experience wheel slipping or sliding, or where wheel traction or mower stability and control are in doubt. The product may slide even if the wheels are stopped. These conditions increase the risk of roll over.

- Never operate on a slope greater than 15 degrees - a slope that has 5.4 feet of elevation change over any 20 foot segment. See **Slope Identification Guide** (Reference 2.4.9) in this Operator Manual.
- Always mow slopes in the up and down direction, never side to side.
- Reduce speed and use extra care when mowing on slopes. If you cannot back up the slope or if you feel uncomfortable, do not drive on the slope.

- Avoid turning the product down slopes. Turn up slopes.
- Always keep the product in gear when going down slopes. Do not coast downhill.
- Avoid starting and stopping on slopes. Avoid making sudden changes in speed or direction. Make turns slowly and gradually.
- Avoid mowing grass that is slippery, wet, or soft. Operating on wet or soft slopes can cause loss of control, which can lead to tip over.
- Use extra care while operating the product with a grass catcher or other attachments. They can affect the stability of the product.

2.4.9 SLOPE IDENTIFICATION GUIDE

▲ WARNING

To reduce the risk of serious personal injury or death, never operate on slopes greater than 15 degrees. Always check the degree of slope on the lawn surface before attempting to mow in that area.

- Download an inclinometer app onto your mobile device that measures slopes.
- Place a flat piece of wood or metal, 4-6 feet in length, on the surface of the slope.
- Open the app and place your phone (2) on the flat piece of metal or wood (1) to determine the exact slope of your lawn. Do not mow if the slope is greater than 15 degrees.

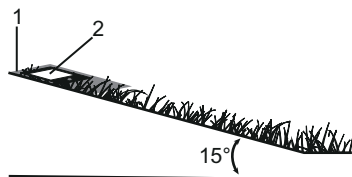

2.4.10 DROP-OFFS AND WATER

▲ WARNING

Drop-offs around steps and water are a common hazard. Never operate your mower down a slope towards water, a retaining wall, or other drop-off. Use extra caution when operating the mower in the vicinity of such hazards.

▲ WARNING

To reduce the risk of falling into water, down steps, or over the edge of a drop-off, always leave yourself two mower widths of clearance between your mower and the hazard. Failure to maintain sufficient clearance may result in serious injury, death, or drowning.

2.4.11 SAFETY INTERLOCK SYSTEM

This mower features a Safety Interlock System consisting of the parking brake, operator presence switch, PTO switch and start key to protect the operator and others from accidental injury due to unintentional start. Test the system before each use to ensure it is working properly.

1. The operator must be on the seat when testing the operator presence switch.
2. Insert the start key and turn to ON position.
3. Release the parking brake.
4. Pull the PTO switch to engage the blades.
5. Slowly stand up from the seat. The mower blades system should stop.

The blades should shut off within 3 seconds. If they don't, immediately contact customer service. Do not operate the mower until the safety interlock system has been repaired.

2.4.12 SERVICE

- Keep product in good working order. Replace worn or damaged parts.
- Use caution when servicing blades. Wrap the blade(s) or wear gloves. Replace damaged blades. Do not repair or alter blade(s).
- Do not charge ride-on mower in rain, or wet locations.
- Store idle ride-on mower indoors - When not in use, ride-on mower should be stored in an indoor dry and locked-up place - out of reach of children.
- Turn off and remove start key before servicing, cleaning, or removing material from the ride-on mower.

Save all warnings and instructions for future reference.

3 ASSEMBLY

3.1 INSTALL THE SEAT

1. Lift the seat panel.

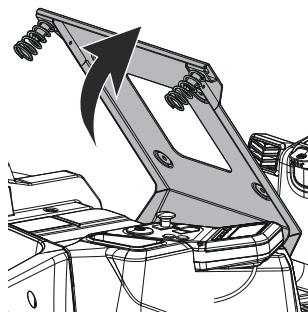

- Place the seat assembly over the seat panel and align holes.

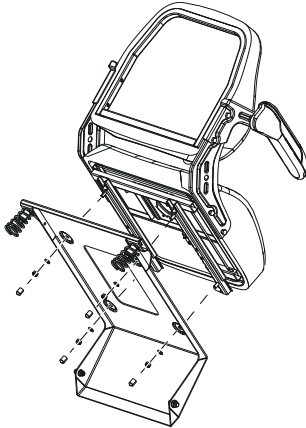

- Install the bolts, washers and nuts and tighten securely with a 10 mm socket and torque to 11-15 ft-lbs (15-20 N.m).
- Connect the wire connector to the seat plug under the seat.

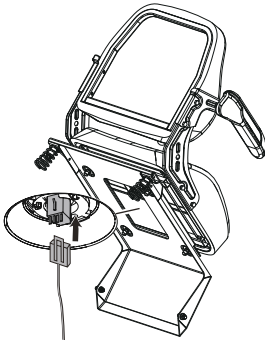

3.2 INSTALL THE STEERING CONTROL LEVER

The two levers control the mower's speed, direction, stopping, neutral lock, and parking brake. Levers are used to steer, accelerate, decelerate, stop, and change direction.

▲ WARNING

The left and right steering levers should be adjusted so that they align with each other when in the neutral position. NEVER install the steering levers in an asymmetrical operating height.

- Lift the steering control lever to align the holes in the lever with the holes in the mounting pole.

- Select the preferred steering-lever operating height. Insert the screw together with the washer into the hole.

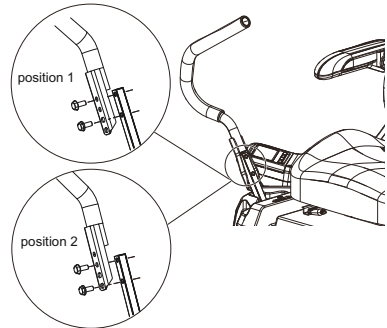

- Use the 16 mm wrench to securely tighten the steering lever with the torque range of 15-22 ft-lbs (20-30 N.m).
- Install the opposite side ensuring both handles mirror each other.

▲ CAUTION

Do not install the steering control lever reversely.

Note: Always drive with both hands on the steering control levers. Do not drive with just one hand.

4 FEATURES AND CONTROLS

The following section provides a brief description of the function of individual controls. For information on starting, stopping, driving, and mowing, refer to the **Operation** (Reference 6) section.

4.1 PRODUCT CONTROLS

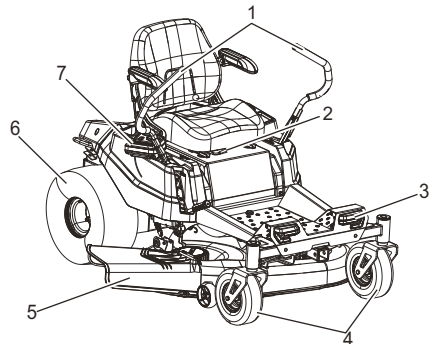

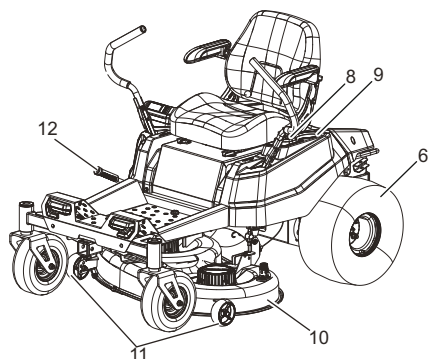

- | | |
|---------------------------|---------------------------------|
| 1 Steering control levers | 7 Control panel |
| 2 Seat adjustment lever | 8 USB port |
| 3 Headlight | 9 Cup holder |
| 4 Front wheels | 10 Cutting deck |
| 5 Discharge chute | 11 Anti-scalp wheels |
| 6 Drive wheels | 12 Deck height adjustment lever |

4.1.1 STEERING CONTROL LEVER

The steering control levers control the direction of the mower.

FRONT OF MOWER FACES THIS DIRECTION

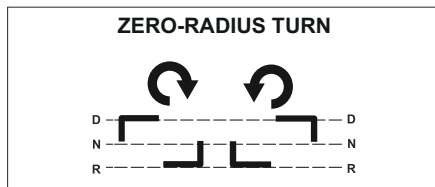
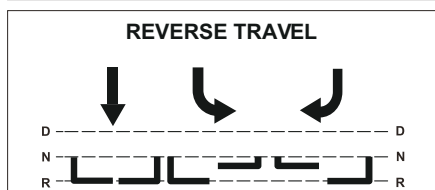
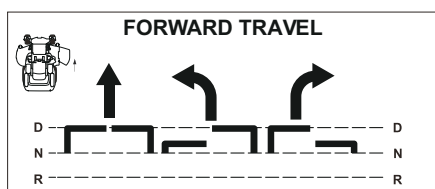

N = NEUTRAL POSITION

D = DRIVE POSITION

R = REVERSE POSITION

Direction of arrows indicate direction of mower movement



Left steering control lever



Right steering control lever

The left steering control lever controls the left rear drive wheel and the right steering control lever controls the right rear drive wheel.

Tilting both steering control levers outwards from the NEUTRAL position will engage the parking brake.

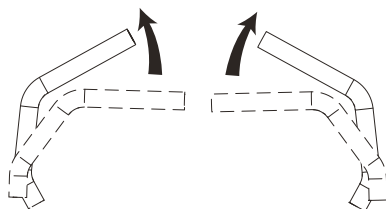

Tilting steering control levers in towards the NEUTRAL position will disengage the parking brake.

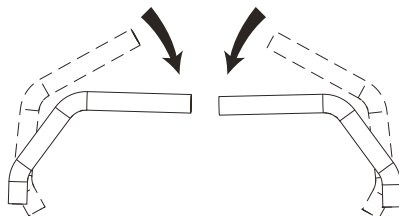

Note: The further a steering control lever is moved away from the neutral position, the faster the drive wheel will turn.

See the **Zero-turn Mower Driving Practice** section (Reference 6.4) for steering instructions.

4.1.2 SEAT ADJUSTMENT LEVER

The position of the seat can be adjusted forwards or backwards to meet the comfort needs of the operator.

1. Sit down on seat and lift the seat adjustment lever.

2. While holding the lever, slide the seat to the desired position.

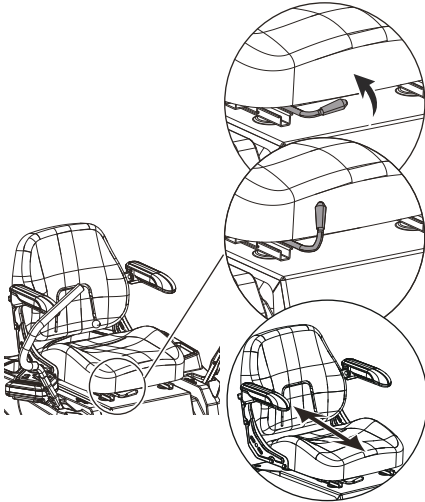

3. Release the lever and make sure the seat is locked before operating the mower.

▲ WARNING

Be sure the seat is locked before operating the mower. A seat that is not secure can cause the operator to shift and lose control of the mower and result in possible death or serious personal injury.

4.1.3 CONTROL PANEL

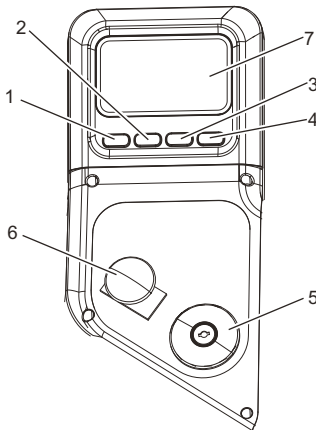

1. **Blade Speed / Back Button:** Adjust the blade speed (cyclic). / Return to previous page.
2. **Menu / Page Up Button:** Menu / Navigate page up.

3. **Lights / Page Down Button:** Activate lights / Navigate page down.

4. **Drive Speed / Confirm Button:** Adjust the drive speed (cyclic). / Press to confirm.

5. **Ignition Switch:** This switch is used to turn the mower on and off. The start key must be inserted before the switch can be operated.

6. **Power Take-off (PTO) Blade Switch:** This switch engages the blade motors. Pull the switch up to engage and push switch down to disengage the motors.

▲ CAUTION

Do not engage PTO switch when the deck is under load. Failure to do so may damage the motor and/or deck.

7. **Digital Display Screen:** This digital display screen shows important electrical system information.

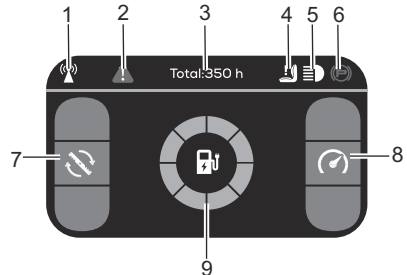

#	Name	Function
1		4G GPS Signal
2		Error warning. Check the error code.
3	Total: 350h	Working time
4		User presence needed to operate.
5		LED Lights activated.
6		The parking brake is engaged. If the icon is blinking, neutral bypass function is activated.
7		Blade speed
8		Drive speed
9		Battery level

4.1.4 USB CHARGING PORTS

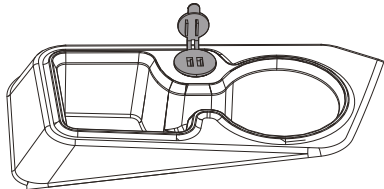

The USB charging port on the mower supplies 5 Volts DC with a maximum current of 2.1 amps for charging your cell phone, MP3 player, or other USB devices. Please refer to your device's owner's manual for its specific charging requirements. To charge your device, connect one end of a USB cable (cable not included) to your device and the other end to the USB charging port on the mower.

Note: Attempting to charge devices rated more than 2.1 amps could damage the USB charging port and/or the mower.

Note: The USB port is only powered when the product is ON.

4.1.5 ANTI-SCALP WHEELS

Anti-scalp wheel kits are standard on Greenworks units. These anti-scalp wheels are designed to minimize scalping when mowing on rough, uneven terrain. After setting the cutting height, adjust the anti-scalp wheels so they extend below the deck but do not contact the ground. They should always be at least 0.6 cm to 1.9 cm below the deck (1). With the unit sitting on a flat level surface, the wheel position can be adjusted up or down as needed from 1.9 cm to 4.4 cm from the anti-scalp wheels (2) to the ground. Move the wheels up or down - using the different axle mount holes in the wheel mount bracket (if applicable on model).

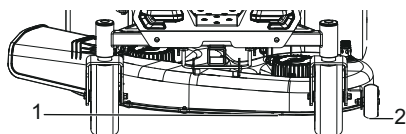

1. After adjusting the cutting height, adjust the anti-scalp wheels by removing the locking flange nut, the hex bolt which fix the wheels.
2. Select a hole so that the wheel is positioned to the corresponding height-of-cut desired.

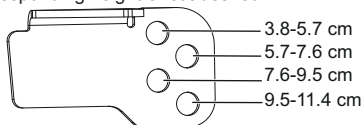

Note: For cutting height over 114mm use the bottom hole. The anti-scalp wheels will be effective against scalping.

3. Install the locking flange nut and the hex nut.
4. Repeat the adjustment on the other anti-scalp wheels.

4.1.6 DECK HEIGHT ADJUSTMENT LEVER

Before using the mower, raise the deck height to the cutting position best suited for your lawn.

Deck height is adjustable from 3.8-11.4 cm. Deck should be raised to avoid stumps, rocks or other obstacle that might damage mower deck.

▲ CAUTION

Grasp and securely hold the deck height adjustment lever when setting it, only releasing it once it's securely in the desired slot to avoid potential hand hazards.

1. Stop the mower and disengage blades.
2. Turn the key to OFF position and set the parking brake.
3. To raise the cutting deck, grasp the deck height adjustment lever, push right to disengage from the slot, lift the lever, then insert back into the desired slot to secure.
4. To lower the cutting deck, grasp the deck height adjustment lever, push right to disengage from the slot, move toward the front of the mower, then insert back into the desired slot to secure.

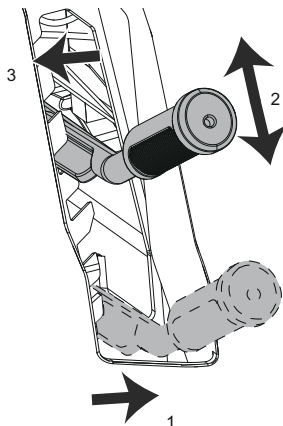

4.1.7 REAR TRAILER HITCH

▲ WARNING

Towing loads can be risky, especially on slopes.

- Max total weight (trailer & load) should not exceed 300 lbs (136 kg).
- Max tongue weight should be under 45 lbs (20.2 kg).
- Avoid slopes over 10 degrees.
- Slow down and be cautious on slopes.
- Do not tow with a grass catcher.

Secure the trailer using the appropriate clevis pin (1) and R pin (2).

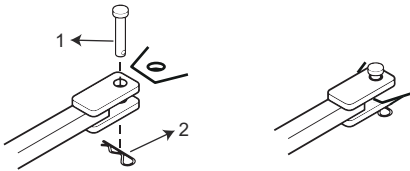

Excessive towed loads affect traction and control on slopes. Lighten the load on slopes. Surface conditions impact traction and stability. Wet or slippery surfaces reduce traction, impacting stopping and turning.

Evaluate the terrain before using the unit and trailer, avoiding slopes steeper than 10 degrees.

5 ELECTRICAL SYSTEM

5.1 ELECTRICAL SYSTEM SAFETY

To reduce the risk of serious personal injury from fire or electric shock when working on the electrical system:

- Always remove the start key and batteries, and read operator manual before working on this product.
- Always remove the start key and batteries when transporting the product.
- Keep the product free of grass clippings, leaves and other debris. DO NOT use water to clean the product. Use only compressed air. Wear adequate eye and hearing protection when cleaning the product.
- Always wear protective gear (safety glasses, face shield and gloves) when working with the battery. Use insulated tools.
- Clean the product of all dirt and debris. Do not use solvents, hard cleaners or abrasives.
- Keep the area clear of bystanders when engaging the PTO switch.
- Never allow flames, sparks or smoking near the product or batteries.
- Keep the product and batteries out of reach of children.

- Always keep protective shields, covers and guards in place and securely fastened. If they become damaged, repair or replace immediately. Never modify or remove safety devices.

5.2 ELECTRICAL SYSTEM INFORMATION

The mower is powered by a 60-volt electrical system. It consists of the following components:

1. Blade controller (1)
2. Blade motor (2)
3. Drive controller (1)
4. Accelerator - right (1)
5. Accelerator - left (1)
6. Digital display (1)
7. Wheel motor (2)
8. Battery (6)
9. Battery compartment (1)
10. Headlights (2)

6 OPERATION

This section describes how to operate the product.

▲ WARNING

CAREFULLY READ AND UNDERSTAND THE SAFETY CHAPTER AND OPERATION INSTRUCTIONS BEFORE YOU OPERATE THE PRODUCT.

6.1 CHARGING

6.1.1 REMOVE THE SECURITY BLOCKS

The product is shipped with the securing and weatherproofing units to protect the batteries and charger from theft.

1. In order to keep battery from latching and engaging contacts, a small red foam is placed in each battery slot. Open the battery compartment cover, and remove each battery to take away the red foam in each slot.

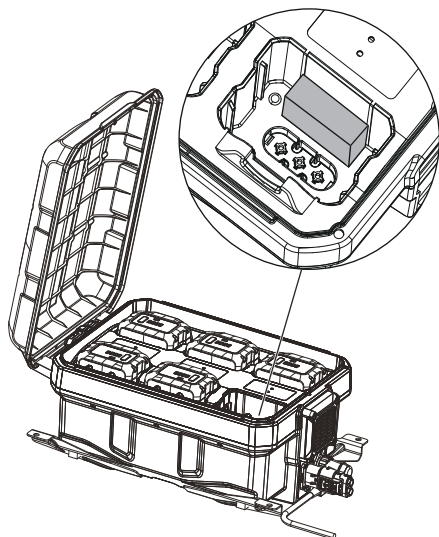

2. Then reinstall the batteries into the slots. The battery locks into position when you hear a click.

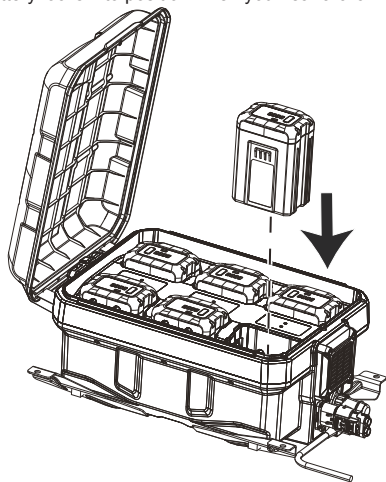

▲ WARNING

Only use original Greenworks batteries with the product.

▲ CAUTION

If the battery does not move easily into the battery compartment, the battery is not installed correctly. This can cause damage to the product.

Note: Press the battery release button to remove each battery.

6.1.2 CHARGE THE BATTERY

The batteries can be charged separately with specific charger (if provided). Connect the battery charger to the proper voltage and frequency that is specified on the rating plate.

Refer to the Battery & Charger Operator Manual for information about how to use the battery charger.

6.1.3 CHARGE THE PRODUCT

1. The charging port is located at the rear part of the mower. Open the port cover from the battery charging port on the mower.
2. Plug the charger into the battery charging port, and make sure it is firmly plugged in.
3. Plug the charger into a power outlet, and make sure it is firmly plugged in.
4. When the mower is charging, the digital display will show the battery percentage.

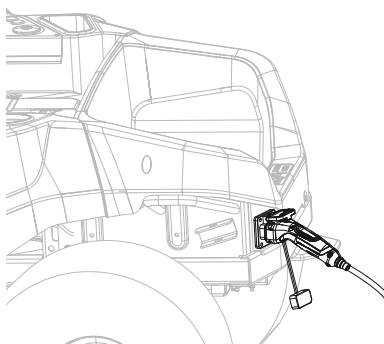

▲ WARNING

See the Battery Charger Manual for warnings and instructions for charging. Read and understand all its safety warnings and instructions. Failure to follow them may result in electrical shock, fire and/or serious injury.

▲ WARNING

To reduce the risk of fire and explosion, keep open flames and sparks away from the mower and its batteries. Ensure proper ventilation around the mower while charging.

Charging recommendations:

- The battery does not need to be fully discharged before recharging. To maintain proper state of charge calibration, run and charge the mower at least once a month. Complete a full charge every six months.

- A battery left uncharged will slowly discharge. Before initial use each spring season, be sure battery has a full charge before mowing.
- Check the battery every six months and charge the battery if the power level is below 50%.
- When the battery level is lower than 5%, the blade motor will stop automatically, and the max driving speed will be 6.4 km/h. The mower needs to be charged immediately.

Note: Cover the battery charging port with the port cover before mowing to prevent foreign objects from entering and causing any damage to the port.

6.2 APP OPERATION TIPS

6.2.1 REGISTRATION AND LOGIN

1. Scan the QR code of app below, download the app.



2. According to the prompts, create an account and then log in.
3. Add a device by typing in serial number and pairing code or by scanning QR code on matching label.

Note: The QR code on vehicle matching label on this manual is generated from serial number and pairing code.

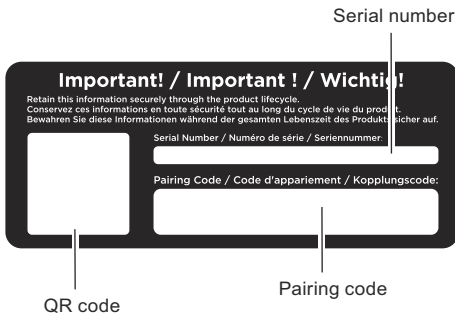

4. The product is equipped with GPS function, you can connect your mobile phone to the product by the APP. It is convenient to locate your product and achieve anti-theft effect.

▲ WARNING

The 4G & GPS connectivity device may lose the GPS satellite signal or cellular connection at any time due to heavy tree canopies, large buildings, poor weather conditions, electrical interference, dead zones, or other obstacles.

6.3 START THE PRODUCT

Note: Clear the area of bystanders before operating the mower. If anyone enters the mowing area, stop immediately and do not return to mowing until the bystanders leave the area.

1. Raise the mower deck to its highest position.
2. Insert the start key and turn to ON position.



3. Pull steering control levers inward to the NEUTRAL position.

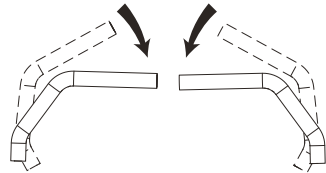

4. Pull up on deck PTO switch to engage blades for mowing.

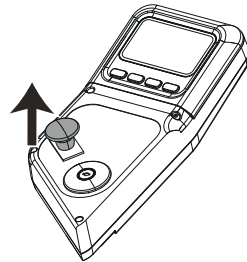

Note: Engage blades only after steering control levers are moved into the NEUTRAL position. NEVER engage blades when moving!

5. Push steering control levers forward for forward motion and pull for reverse motion.

Note: Use caution when crossing over gravel paths or driveways. Before crossing, disengage the blades and raise the cutting deck to the highest position to minimize the possibility of ricochet. Drive slowly to avoid loss of traction and control.

Note: Do not attempt to change the direction of operation while the mower is in motion. Always

come to a complete stop before changing the mower direction.

Note: Steering control levers will spring back towards the neutral position only if released from reverse position, so it is important to manually guide them to reach the neutral position.

6.4 ZERO-TURN MOWER DRIVING PRACTICE

Prior to operating the mower, ensure you have studied the **Features And Controls** (Reference 4) section to grasp control functions. Using the steering control levers to master smooth and efficient control over forward, reverse, and turning requires practice. Familiarize yourself with acceleration, travel, and steering by practicing maneuvers in a clear, open lawn area, free of obstacles and hazards. Drive at low speeds to prevent tire slippage and lawn damage. Start with the smooth travel procedure and progress through forward, reverse, and turning maneuvers.

6.4.1 SMOOTH TRAVEL

The mower's steering control levers are quick to respond. The optimal approach for managing these handles involves three steps:

1. Place your hands onto the levers.
2. To move forward slowly, push the levers forward with your palms.
3. To reach the maximum of the set speed, move the levers farther forward. For a gentle deceleration, move the levers towards neutral.

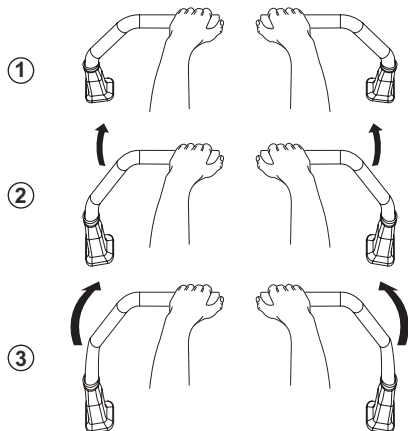

6.4.2 BASIC DRIVING

Forward Travel Practice

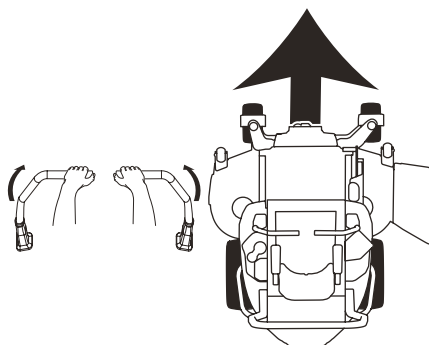

Move both steering control levers evenly and gradually forward from neutral. Practice slowing down and repeating.

Note: Mastering straight forward travel requires practice. Adjust the speed as needed.

Reverse Travel Practice

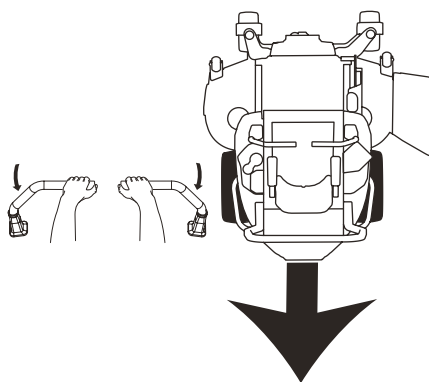

Look behind and down, then gradually pull both steering control levers evenly back from neutral. Practice slowing down and repeating.

Note: Spend several minutes practicing reverse before doing so near objects. Remember, the mower turns sharply in reverse, similar to forward motion, and backing up straight requires practice.

6.4.3 PRACTICE TURNING AROUND A CORNER

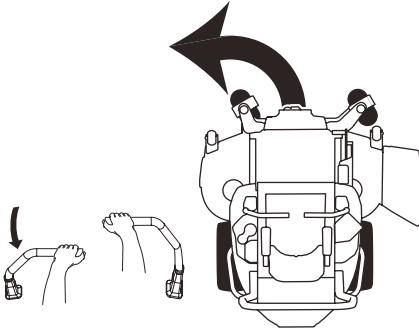

While moving forward, gently bring one steering control lever back towards neutral. Practice this repeatedly.

Note: To prevent pivot directly on the tire tread, ensure both wheels maintain a slight forward motion.

6.4.4 PRACTICE TURNING IN PLACE

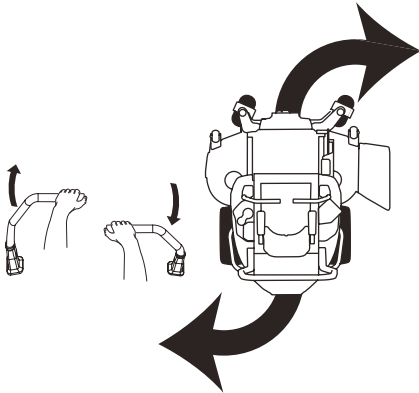

For a "zero-turn" maneuver, gradually move one steering control lever forward from neutral while moving the other handle back from neutral simultaneously. Practice this several times.

Note: Adjusting the extent of pulling each steering control lever forward or back alters the turning "pivot point."

6.4.5 ADVANCED DRIVING

Your zero-turn mower's exceptional feature of turning in place allows you to pivot at the row's end instead of stopping and performing a Y-turn before commencing a new row.

Here's how to execute a left end-of-row zero turn:

1. Gradually decelerate at the row's end.

2. Slightly push the RIGHT steering control lever forward while moving the LEFT steering control lever back to its center and then slightly back.
3. Resume forward mowing.

By adopting this approach, the mower turns left and slightly overlaps the recently cut row, eliminating the necessity to backtrack and recut any missed grass.

6.5 STOP THE PRODUCT

▲ DANGER

Never make sudden stops or reverse direction, especially when maneuvering on a slope. The steering is designed for sensitive response. Rapid movement of the steering control levers in either direction could result in a reaction of the product that can cause serious injury.

1. Drive the mower to a flat, level surface and return the steering control levers to the NEUTRAL position to stop the mower's movement. Push the steering control levers outward to engage the parking brake.

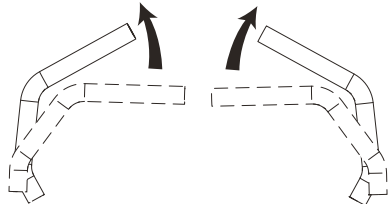

2. Push PTO switch to disengage the blades.
3. Rotate key to the OFF position.

▲ CAUTION

It is recommended to remove the start key from the product to prevent accident start of the product.

6.6 MOWING

Select a smooth, level area to mow. Be cautious of trees, fences, and slopes. Mow in straight lines, slightly overlapping. Occasionally change patterns to prevent flat spots. For a professional touch, mow across once and then go perpendicular on the next round.

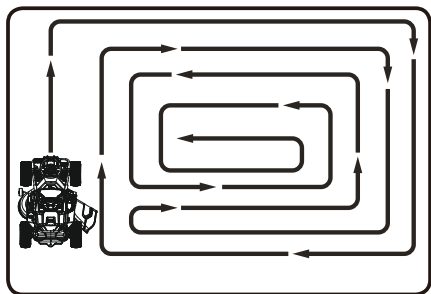

When mowing expansive spaces, begin by turning towards the right to ensure that clippings are directed away from shrubs, fences, driveways, and other areas. After completing one or two rounds, mow in a back-and-forth pattern across the lawn, pivoting at the edges of the previously mowed grass.

6.7 MOWING PATTERNS

6.7.1 SIDE-DISCHARGING

Side-discharging is a mowing technique that efficiently processes a larger volume of grass in a single pass. This method involves expelling grass clippings to the side of the mower deck and dispersing them across the lawn. The side-discharge deck design allows for effective cutting, making it ideal for larger areas where expedited mowing is essential. For optimal mowing, set blade speed to the highest speed (if applicable). If the motor slows, reduce drive speed. Slower drive speed boosts blade efficiency and prevents cutting issues. Choose side-discharging mowing for 75-125 mm grass. Avoid cutting more than 25mm at once.

6.7.2 MULCHING

Mulching offers versatile benefits, finely cutting grass and returning clippings to the soil. Remember, mulching works best on dry and moderate-height grass. For successful mulching, set the blade speed on the highest speed (if applicable) and match it with the slowest driving speed. This ensures finely cut clippings. When mulching, drive at about half the speed used for side discharging.

Optimal Clipping Length

Ideal mulching trims just the top 12-20 mm of grass, resulting in decomposing clippings. Experiment with cutting height based on your climate, season, and lawn thickness. As always, mow thoughtfully and consider your lawn's unique conditions for the best results.

6.8 MOWING RECOMMENDATIONS

Multiple factors impact your mower's grass-cutting efficiency. Adhering to mowing guidelines enhances performance and longevity.

6.8.1 HEIGHT OF GRASS

Cutting height often depends on preference. Typically, mow when grass is 7-12 cm high. Proper height varies based on grass type, rainfall, temperature, and lawn health. Cutting too short weakens grass and makes it prone to damage by dry periods and pests. Slightly longer grass is less prone to damage. Longer growth in hot, dry conditions reduces heat stress, conserves moisture, and guards against damage. Keeping the grass too long leads to thin turf and problems. Don't cut too much at once; follow the 1/3 rule: trim a maximum of 1/3 and no more than 3 cm at a time.

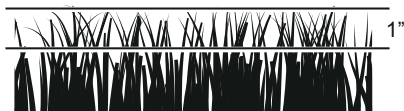
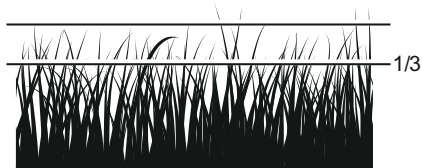

Mowing capacity depends on your chosen mowing system. Broadcasting with side discharge decks handles more grass than mulching. Tall grass needs gradual cutting. For very tall grass, begin with max height (1), then lower it for the second (2) or third pass. Avoid leaving excessive clippings on top of the grass. Consider a grass collection system or composting. Remember, different systems are suited to different situations.

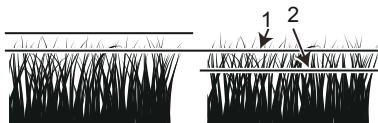

6.8.2 WHEN AND HOW OFTEN TO MOW

The timing and grass condition significantly influence mowing outcomes. Follow these guidelines for best results:

- Mow when grass height is between 75-125 mm.
- Use sharp blades for precision. Short clippings under 25 mm decompose faster, and sharp blades prevent frayed edges.
- Choose a cool and dry time of day for mowing, like late afternoon or early evening.
- Avoid mowing after rain or heavy dew. Never mulch wet grass as it clumps beneath the mower deck and doesn't mulch effectively.

7 TRANSPORTATION

7.1 TRANSPORT THE MOWER

▲ CAUTION

Do not tow this mower, it may cause damage to the drive system.

▲ WARNING

Do not load mower on a trailer or truck using two separate ramps. Only use a full-width ramp that is at least 305 mm (1 ft) wider than the width of the rear wheels of the mower. The rear wheels could fall off the ramps or the unit could tip over injuring the operator or bystanders. Ensure the cutting deck is raised to the highest position so it does not get caught on the ramp.

1. Park the mower on a level surface.
2. Raise the cutting deck to the highest position.
3. Position and secure ramp to the trailer according to manufacturer's instructions.
4. Use a full-width loading ramp that is at least 305 mm (1 ft) wider than the mower to reduce the risk of driving off the side of the ramp.
5. Slowly drive the mower onto the ramp and into the trailer.
6. Set the parking brake.
7. After loading, lower mower deck completely.
8. Secure the mower as needed using straps or cables to prevent movement during transport.

▲ WARNING

To avoid accidental starting or movement that could result in serious personal injury, always remove the start key and engage the parking brake when transporting the mower.

7.2 TRANSPORT THE LITHIUM-ION BATTERY

The US Department of Transportation and international transportation authorities require that lithium-ion battery be transported using special packaging and only be transported by carriers certified to haul them. In the US, you are allowed to transport a battery when it is installed on the mower as battery powered equipment, with some regulatory requirements. Contact the US Department of Transportation or the appropriate government body in your country for detailed regulations on transportation of your battery or the mower with the battery equipped. For detailed information on shipping a battery, contact your authorized Greenworks servicing dealer.

7.3 MOVE THE MOWER MANUALLY

To push the mower manually:

1. Disengage the blades and push the steering control levers outward to engage the parking brake.
2. Turn the start key to the OFF position. Remove the start key, and wait for all moving parts to stop before leaving the operating position.
3. Return the steering control levers to the NEUTRAL position then unlock the neutral bypass levers to disengage the drive system.
4. Move the mower to the desired location.

▲ CAUTION

To avoid damage to the motor and drive system, do not move the product faster than 5 mph (8 km/h).

5. Immediately after moving the mower, lock the neutral bypass levers.

7.4 NEUTRAL BYPASS LEVER

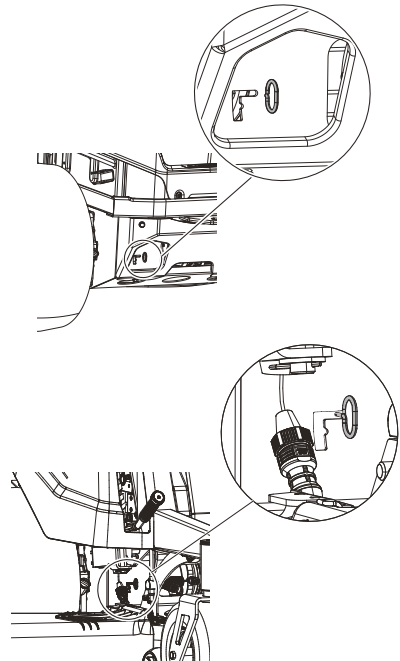

1. Pull the two neutral bypass levers outwards and then downwards to unlock the wheels.

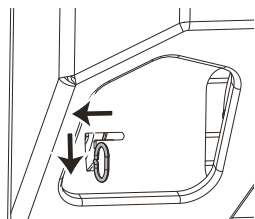

2. Move the neutral bypass levers back into position to lock the wheels.

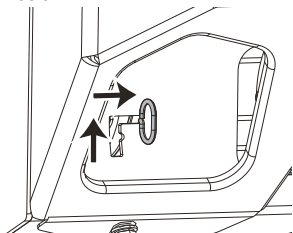

▲ WARNING

Never drive mower with the neutral bypass lever working. Always install the neutral bypass lever to the original position before driving! Failure to re-install the lever could cause serious damage to your mower and void mower warranty!

▲ WARNING

Never unlock the neutral bypass lever when the product is working on a slope.

8 CLEAN AND STORAGE

8.1 CLEAN THE PRODUCT

- Remove any build-up of grass and leaves on or around the motor cover (Do not use water).
- Occasionally wipe the mower clean with a dry cloth.
- If debris builds up on the underside of the mower during use, stop the motor on level ground, disengage the blades, set the parking brake, shut off the product, remove the start key and use the compressed air to clean the area.

8.2 CLEAN THE MOWER DECK

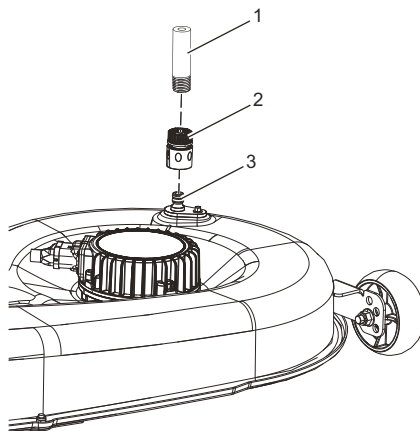

- Prepare the mower by parking it, setting the brake, and lowering the mower deck.
- Connect the hose (1) with quick-coupler (2) to the wash port (3), turn on the water, start the mower blades with increased speed, and flush under the deck for about one minute.
- Finish cleaning by disengaging the mower blades, turning off the water, and disconnecting the hose.
- Store the quick-coupler for future use.
- Shut down the mower completely.

8.3 STORE THE PRODUCT

The following steps should be taken in order to prepare the product for storage.

- **Clean the Mower:** Before storing the product, thoroughly clean it as outlined in the previous section.
- **Blade Inspection and Maintenance:** Inspect the blades and replace them as detailed in the **Service the Mower Blades** (Reference 9.8) section if needed.
- **Avoid Corrosive Materials:** Keep the mower away from corrosive substances, such as fertilizer or rock salt, as these can lead to rust and corrosion on metal components like the blade, deck, motor, and frame. Keep the mower and its battery away from conductive or corrosive materials to reduce the risk of short circuit, fire, explosion and other electrical hazards.
- **Children Safety:** Store the product in a location inaccessible to children to prevent accidents.
- **Proper Covering:** Do not cover the product with a solid plastic sheet. Plastic coverings can trap moisture, which causes rust and corrosion.

- **Check for Wear and Tear:** Thoroughly inspect the mower for any worn or damaged parts that may require replacement.
 - **Tire Maintenance:** Avoid deflating the tires during storage.
 - **Storage Environment:** Store the product in a well-ventilated, clean, and dry area. Note that the battery charger cannot be used in a wet environment.
 - **Charging Process:** Refer to the **Charging** (Reference 6.1) section and also the Battery Charger Manual for comprehensive instructions on using the charger and effectively charging the battery.
- Note:** *By adhering to these guidelines, you can help increase the longevity of your mower during periods of storage.*

9 MAINTENANCE

9.1 MAINTENANCE SAFETY

- Specific steps must be taken in order to perform service and maintenance procedures safely.
- Read and follow all the applicable safety and instructional messages in this manual.
- Always disengage the mower blades, set the parking brake, shut the mower off, remove the start key, remove the batteries and wait for all movement to stop prior to performing service and maintenance procedures.
- Wear appropriate personal protective equipment such as safety shoes, safety glasses, gloves and ear protection. Long hair, loose clothing or jewelry may get tangled in moving parts. Secure hair above shoulder level before starting work.
- Use of parts that are not authorized or approved by Greenworks may cause serious or fatal injury or property damage.

9.2 BATTERY MAINTENANCE

The mower is powered by Lithium-Ion batteries which, when maintained properly, will provide years of useful life. For proper care, adhere to the following instructions:

- Always charge battery after each use. This is especially crucial when temperatures drop below 32°F (0°C). Over-discharge will shorten battery life and risk permanent damage. If a full charging cycle is not possible immediately after cutting, a 5-10 minute cycle will help maintain battery health. Fully re-charge the battery within 24 hours after use. To maintain proper calibration, run and charge the mower at least once a month. Complete a full charge every six months.
- Keep grass, dirt and debris from collecting in battery area.
- Charge battery in an enclosed, dry area away from sparks and flames. Never expose charger to rain, water vapor or other liquids.
- Do not touch uninsulated portion of charger (terminal pins) or output connector.
- Do not use charger if cords are damaged.
- Please refer to the Battery Manual for more information of batteries.

9.3 RECOMMENDED MAINTENANCE SCHEDULES

Maintenance Service Interval	Maintenance Procedure
After the first 2 hours and then every 100 hours	<ul style="list-style-type: none"> Check the wheel-lug nuts.
After the first 50 hours and then every 200 hours	<ul style="list-style-type: none"> Replace the gearbox oil.
Before each use or daily	<ul style="list-style-type: none"> Inspect the blades. Check the contacts of switches and brakes. Check for frayed and deteriorated insulations. Inspect the tires. Replace the battery compartment filter if it is dirty. Clean under the cutting deck. Clean the area under the operator's seat and near the battery. Remove all grass clippings, leaves, and debris from the product before starting work.
Every 50 hours	<ul style="list-style-type: none"> Check the tire pressure.
Before storage	<ul style="list-style-type: none"> Remove the battery and key fob from the product. Perform all maintenance procedures and thoroughly clean the product. Inspect the entire product for damaged, missing, or loose parts, replace or tighten the corresponding ones before storage. Paint chipped surfaces.

9.4 CHECK TIRE PRESSURE

Tire pressure should be checked periodically, and maintained at the levels shown below. Notice that these recommendations may differ slightly from the "Max Inflation" stamped on the side-wall of the tires. Exceeding the max inflation will lead to a tire explosion. The pressures shown provide proper traction and extend tire life.

Front caster wheels	37 psi
Drive wheels	8 psi

9.5 TORQUE VALUES

▲ WARNING

Particular attention must be given to tightening the drive wheel lug nuts and blade spindle bolts. Failure to correctly torque these items may result in the loss of a wheel or blade, which can cause serious damage and/or personal injury.

Torque values are given below:

Part	Ft.-lbs.	N.m
Wheel lug nuts	70-77	90-105
Blade spindle bolts	118	160

Wheel lug nuts only: It is recommended that these be checked after the first 2 hours of operation initially, then every 100 hours and following removal for repair or replacement.

9.6 LUBRICATION

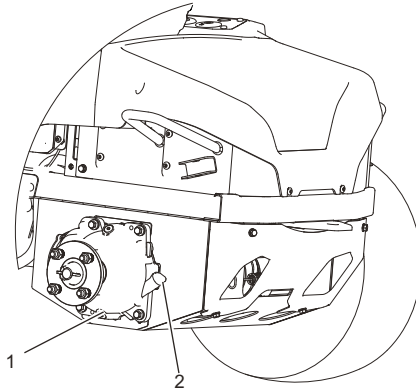

Add oil from the oil ruler (2) before operation. Drain oil from the oil drain outlet (1).

Oil type	SAE85W-140
Oil capacity	130 ml (0.14 quarts)

Contact your Greenworks dealer to replace the lubrication.

Note: Replace the gearbox oil after the first 50 hours of operation, and subsequently, replace the oil every 200 hours.

9.7 SIDE DISCHARGE TO MULCHING(OPTIONAL)

The product is configured for side discharge when shipped. If mulching is desired:

1. Lift the side discharge chute, and place the mulch cover in the space provided.

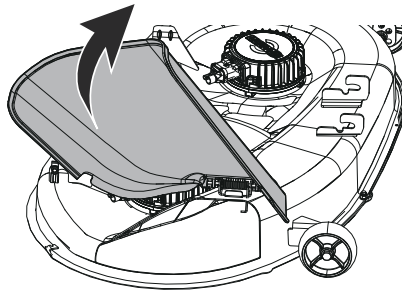

2. Align the holes in the mulch cover and the holes in the mower deck.

3. Install and tighten all the bolts, washers, fixed seat and nuts as shown.

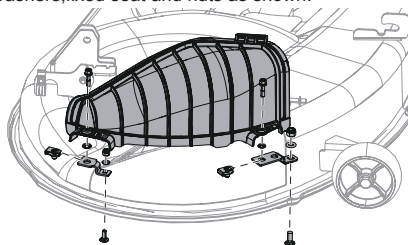

Note: The square mounting holes on the deck are intended for the bolts with square necks to insert through the bottom of the deck.

9.8 SERVICE THE MOWER BLADES

9.8.1 MOWER BLADE MAINTENANCE

Inspect the mower blades on a daily basis. They are crucial for power efficiency and optimal mowing. Ensure they are sharp, as a dull blade can cause tearing instead of cutting, resulting in a brown and ragged appearance on the grass within a few hours. Additionally, a dull blade requires more power. Replace any blades that are bent, cracked, or broken.

▲ WARNING

Never attempt to straighten a bent blade by heating, or weld a cracked or broken blade as the blade may break and cause serious injury. Replace worn or damaged blades.

▲ WARNING

Never work with blades while the start key is in the ignition switch. Turn the start key to "OFF" position, remove the batteries from the product. Support the mower with certified jack stands when working beneath it. Wear gloves when handling blades. Always check for blade damage if mower strikes a rock, branch or other foreign objects!

- The blade sail (curved part) must be pointing upward toward the inside of the deck to ensure proper cutting.
- Rotate blades after installation to ensure blade tips don't touch each other or the sides of the mower.
- Ensure correct torque on the bolt to prevent potential blade loss, which may result in serious injury.
- Mower blades are sharp and capable of cutting. Always wear gloves and exercise extra caution during servicing.

9.8.2 REPLACE THE BLADE

1. Stop the motor, remove the start key, set the parking brake and remove the batteries from the product.
2. Raise the height of the cutting deck to its highest position to allow access to blades.

Note: If necessary, raise the mower by placing on a lift or using a jack and jack stands, or remove the cutting deck to gain access to the blades. The jack stands should not allow the product to move when the traction drive system is running and the drive wheels are rotating. Use only certified jack stands. Use only appropriate jack stands, with a minimum weight rating of 2000 pounds (907.2 kg) to block the unit up. Use in pairs only. Follow the instructions supplied with the product stands.

▲ WARNING

If raising the mower to access the blades, make sure the mower is properly secured and the parking brake is set before proceeding. Failure to properly secure the mower could cause it to fall, resulting in death or possible serious personal injury.

3. Wedge a block of wood between the blade and mower deck to prevent the blade from turning.

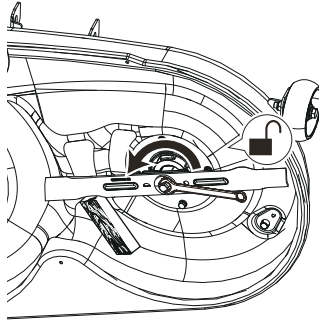

4. Loosen the blade nut by turning it counterclockwise (as viewed from bottom of mower) using a 16 mm wrench or socket (not provided).
5. Remove the blade nut, spacer, blade, and blade insulator.

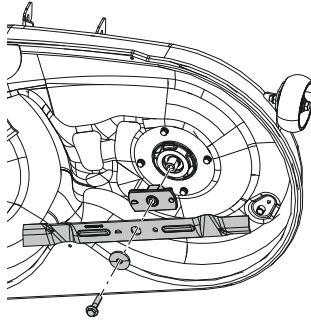

6. Replace with the new blade.
7. Install the blade nut, spacer, blade, and blade insulator in sequence. Ensure that the cutting edge of the blade is oriented toward the deck in the indicated order. Torque the blade nut down clockwise using a torque wrench (not provided) to ensure the bolt is properly tightened. The recommended torque for the blade nut is 66~74 ft.lbs (90 N.m~100N.m).

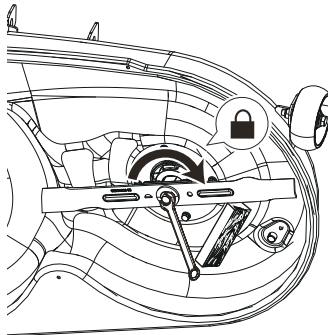

▲ **WARNING**
Ensure blade is properly seated and the blade nut is tightened to the torque specifications above. Failure to properly attach the blade could cause it to come loose and result in possible serious personal injury.

- 8. Repeat with second blade, if needed.

Note: *Make sure all parts are replaced in the exact order in which they were removed.*

10 TROUBLESHOOTING

PROBLEM	POSSIBLE CAUSE	CORRECTIVE ACTION
Product won't move.	There is no battery installed in the battery compartment or the battery is not an official Greenworks battery.	Use only official Greenworks battery (or batteries). At least one is required for operation.
	Battery is not charged.	Charge the battery.
	No one is sitting on the seat or the operator presence switch is not functioning properly.	Make sure the driver is sitting on the seat or ensure that the cable connector is properly plugged to the seat plug.
	The parking brake is engaged.	Make sure you fully disengage the parking brake, so the wheels can rotate freely.
	The battery compartment is in dormant state.	Turn the start key to the OFF position and wait for more than 5 seconds before restarting the product.
Product suddenly stops during driving	Battery is not charged.	Use only official Greenworks battery (batteries). At least one fully-charged battery is required for operation.
	Riding on rough and uneven road conditions cause the operator presence switch to disconnect.	Engage the parking brake, make sure the cable connector is securely attached to the seat plug located under the seat, then restart the product.
	Accelerator pedal failure.	Contact Greenworks after-sales service center.
	Drive controller failure.	Contact Greenworks after-sales service center.
The blade does not operate after pulling the PTO switch.	There is no battery installed in the battery compartment or the battery is not an official Greenworks battery.	Use only official Greenworks battery (batteries). At least one fully-charged battery is required for operation.
	The battery power is lower than 5%.	Check the battery power, if the battery power is low, charge the battery.
	The operator presence switch is not functioning properly.	Ensure the driver is sitting on the seat.
	The blade switch (PTO) is not in the correct position before powering on.	Push the PTO and pull it up again.
	Blade motor blockage or other functional protection.	Make sure there are no weeds or foreign objects at the connection point between the blade and the motor. It is recommended to raise the deck and start the blade to ensure normal operation before adjusting the deck height.
	Walking controller is malfunctioning.	Check the error code on display. Contact greenworks after-sales service center.
The blade stops when mowing grass.	Blade controller is malfunctioning.	Check the error code on display. Contact greenworks after-sales service center.
	Blade motor overload.	Clean the inside of the deck, make sure there is no abnormal blade rotation, press the PTO switch, restart the product and reduce the blade load, either by raising the cutting deck or reducing the driving speed.
	Battery temperature is too high.	Do not use the product immediately after charging, otherwise it may trigger the battery temperature protection error.
	The battery power is lower than 5%.	Charge the battery.

PROBLEM	POSSIBLE CAUSE	CORRECTIVE ACTION
	The blade is hit by a foreign object, causing a sudden stop.	Turn the start key to the OFF position and wait for more than 5 seconds before restarting the product.
	Drive controller is malfunctioning.	Check the error code on display. Contact greenworks after-sales service center.
The mower cuts the grass unevenly, and the height difference is very large.	The blade is blunt.	Sharpen the blades.
	Blade is bent.	Replace the blade according to the manual instructions, and wear protective gear.
	Uneven deck.	Level the deck.
The actual mowing height does not match the marked mowing height chosen.	Deck mounting bolts are loose.	Securely tighten deck mounting bolts. Note: The deck needs to be re-leveled after adjusting the mounting bolts.
	The deck is seriously worn or damaged.	Replace the deck.
Abnormal product shredding	The grass is too wet.	Wait until grass is dry.
	The grass is too tall/dense.	Raise the deck and cut grass with multiple passes, adjusting the height accordingly.
Excessive product vibration	Blade bolts are loose.	Tighten the blade.
	Blade is bent.	Replace the bent blade according to the manual instructions, and wear protective gloves.
	Uneven deck.	Level the deck.
	Deck mounting bolts are loose.	Securely tighten deck mounting bolts. Note: The deck needs to be re-leveled after adjusting the mounting bolts.
	The grass is too tall/dense.	If the grass is too dense and high, please raise the deck, try to avoid cutting heavy grass.
Grass leaves or debris left on the ground after mowing.	The grass is too tall/dense.	Raise the deck and cut grass with multiple passes, adjusting the height accordingly.
	The grass is too wet.	Wait until grass is dry.
	Driving speed is too high.	Lower the driving speed.
	Blade cutting speed is too low.	Increase the blade speed.
Short mowing duration	Grass is too tall/dense.	Raising the deck or decrease blade speed to increase the mower's usage time on one charge.
Mower runaway	Different tire pressure	Check the rear tire pressure of the mower regularly according to the manual instructions.
Product won't start after washing.	Improper cleaning, leading to water entering: the digital display screen, battery compartment, and/or other electronic components.	<ol style="list-style-type: none"> 1. Follow the instructions to clean the product. 2. If the product is accidentally drenched, store the product in a dry place for 12 hours or blow dry before restarting. 3. Contact Greenworks after-sales service center if the problem persists.
The mower is blocked.	Weeds and debris build up on the deck.	Follow the instructions to clean the product after each use.
Product with parking brake slides on slope.	Severe tire wear.	Contact the Greenworks after-sales service center to replace the tires.
	The parking brake is damaged or terribly worn.	Contact the Greenworks after-sales service center to replace the parking brake.

PROBLEM	POSSIBLE CAUSE	CORRECTIVE ACTION
	The parking brake is manually released.	Check the parking brake and reset it to the initial position. Contact Greenworks after-sales service center if the problem persists.

11 TECHNICAL DATA

Model No.	CRZ426
Voltage	60 V
Length	170 cm
Height	117 cm
Width (with discharge)	135 cm
Cutting width	107 cm
Forward speed	6.4/9.6/12.8 km/h
Reverse speed	4.8 km/h
No load cutting speed	3200 RPM
Charger model	CH60LV00 and other CAC series
Battery model	LB6081 and other BAB series

The recommended ambient temperature range

Item	Temperature
Product storage temperature range	32°F – 113°F (0°C – 45°C)
Product operation temperature range	32°F – 113°F (0°C – 45°C)

13 ERRORS

The CANBUS system will take action to protect the user and product when it detects an issue. When it acts to turn off the product or a component, it will indicate that an error has occurred, and that error will be shown on the digital display. All electrical errors have a letter code followed by a number. The first letter describes the system that caused the error according to this chart:

Name	Meaning
TR	Right Driver Controller and motor
TL	Left Driver Controller and motor
PMU	Power management unit (in the battery cabin)
ML	Left blade motor controller
MR	Right blade motor controller
D	Display

Item	Temperature
Battery charging temperature range	43°F – 104°F (6°C – 40°C)
Charger operation temperature range	39°F – 104°F (4°C – 40°C)
Battery storage temperature range	32°F – 113°F (0°C – 45°C)
Battery discharging temperature range	32°F – 113°F (0°C – 45°C)

12 WARRANTY

Greenworks hereby warrants this product, to the original purchaser with proof of purchase, for a period of three (3) years against defects in materials, parts or workmanship (consumer / private usage). Greenworks, at its own discretion, will repair or replace any and all parts found to be defective, through normal use, free of charge to the customer. This warranty is valid only for units which have been used for personal use that have not been hired or rented for industrial/commercial use, and that have been maintained in accordance with the instructions in the owners' manual supplied with the product from new.

13.1 RIGHT WHEEL MOTOR CONTROLLER ERROR CODES

Error Codes	Errors Contents	Suggestions
TR2	Drive motor stalled	1. Check whether the tires are stuck; 2. Check the pin status of the encoder connector corresponding to the motor and whether the connector is connected properly; 3. Check whether the phase wire of the corresponding motor is damaged and whether the phase wire installation is misaligned; 4. Check the parameter version and perform motor self-learning again. 5. Replace the motor and perform motor self-learning again; 6. Replace the controller and perform motor self-learning again.
TR4	Motor overspeed protection	1. Check whether the phase wire of the corresponding motor is damaged and whether the phase wire installation is misaligned; 2. Check the pin status of the encoder connector corresponding to the motor and whether the connector is connected properly; 3. Replace the motor encoder; 4. Perform motor self-learning again. 5. Replace the motor and perform motor self-learning again; 6. Replace the controller and perform motor self-learning again.
TR5	Motor encoder error	1. Check the pin status of the encoder connector corresponding to the motor and whether the connector is connected properly; 2. Replace the motor encoder and Perform motor self-learning again; 3. Replace the controller and Perform motor self-learning again.
TR6	Controller phase loss	1. Check whether the phase wire of the corresponding motor is damaged and whether the mounting screws are tight; 2. Replace the motor and Perform motor self-learning again; 3. Replace the controller and Perform motor self-learning again.
TR7	MOSFET error	Replace the controller and Perform motor self-learning again.
TR8	Controller undervoltage	1. Replace the fully charged battery pack; 2. Replace the controller and perform motor self-learning again.
TR9	Controller overvoltage	1. Replace the battery pack with the same voltage platform; 2. Replace the controller and Perform motor self-learning again.
TR12	Motor overtemperature	1. Check whether the tires are stuck; 2. The motor temperature is too high. Please wait for cooling before use and restart the power supply. 3. Replace the motor and perform motor self-learning again.
TR13	Controller overtemperature	1. Check whether the tires are stuck; 2. The controller temperature is too high. Please wait for cooling before use and restart the power supply. 3. Replace the controller and perform motor self-learning again.
TR14	Software Overcurrent	1. Check whether the phase wire of the corresponding motor is damaged and whether the mounting screws are tight; 2. Check the pin status of the encoder connector corresponding to the motor and whether the connector is connected properly; 3. Replace the controller and perform motor self-learning again; 4. Replace the motor and perform motor self-learning again.
TR15	Hardware Overcurrent	1. Check whether the phase wire of the corresponding motor is damaged and whether the mounting screws are tight; 2. Check the pin status of the encoder connector corresponding to the motor and whether

Error Codes	Errors Contents	Suggetions
		the connector is connected properly; 3. Check the status of the MOS-FET of the controller; 4. Replace the controller and perform motor self-learning again; 5. Replace the motor and perform motor self-learning again.
TR16	Potentiometer error	1.Check the pin status of the potentiometer connector and whether the connector is connected properly; 2. Check whether the potentiometer voltage is within the range of $5V\pm 0.5$; 3. Detect the potentiometer voltage change range to see if there is any abnormal voltage jump; 4. Replace the potentiometer.
TR19	Operating sequence error	1. Check whether the park switch status changes normally; 2. Check whether the right potentiometer voltages exceed the dead zone range; 3. Check whether the seat switch status changes normally.
TR21	ETO relay error	1. Check whether the relay coil resistance is around 30Ω. If it is abnormal, the relay needs to be replaced; 2. Check whether there is a short circuit or open circuit in the wiring between the controller and the relay coil; 3. Replace the controller and perform motor self-learning again; 4. Replace the motor and perform motor self-learning again.
TR22	Electromagnetic valve error	1. Check whether the electromagnetic valve coil resistance is around 24Ω. If it is abnormal, the electromagnetic valve needs to be replaced; 2. Check whether there is a short circuit or open circuit in the wiring between the controller and the electromagnetic valve coil; 3. Replace the controller and perform motor self-learning again.
TR23	Battery compartment (PMU)communication error	1.Check the pin status of the PMU CAN connector whether the connector is connected properly; 2. Check whether PMU CANL and CANH are short circuited or open circuited; 3. Replace the battery compartment; 4. Replace the controller and perform motor self-learning again.
TR24	Battery compartment (PMU)shutdown	1. Restart the vehicle; 2. Check whether key switch and replace it if it is damaged; 3. Check the connector of the battery compartment and replace it if it is damaged; 4. Replace the PMU.
TR25	CAN timeout error - left drive	1.Check the pin status of the CAN connector whether the connector is connected properly; 2. Check whether CANL and CANH are short circuited or open circuited; 3. Replace the controller and perform motor self-learning again.
TR27	CAN timeout error - left blade	1.Check the pin status of the CAN connector whether the connector is connected properly; 2. Check whether CANL and CANH are short circuited or open circuited; 3. Replace the controller and perform motor self-learning again.
TR28	CAN timeout error - Middle blade	1.Check the pin status of the CAN connector whether the connector is connected properly;2. Check whether CANL and CANH are short circuited or open circuited; 3. Replace the controller and perform motor self-learning again.
TR29	CAN timeout error - right blade	1.Check the pin status of the CAN connector whether the connector is connected properly;2. Check whether CANL and CANH are short circuited or open circuited; 3. Replace the controller and perform motor self-learning again.

Error Codes	Errors Contents	Suggestions
TR30	Power off warning	Power has been shut down, please restart the vehicle.
TR31	Seat switch verification error	1. Check the pin status of the seat switch connector whether the connector is connected properly; 2. Check whether there is a short circuit or open circuit in the seat switch wiring; 3. Check whether water has entered the seat switch and whether the status of the switch changes normally; 4. Replace the seat switch; 5. Replace the controller and perform motor self-learning again.
TR32	Software authentication error	1. Restart the vehicle; 2. Replace the controller and perform motor self-learning again.
TR60	Controller undertemperature	The temperature of the controller is too low. Please wait until the temperature rises to above -22.0°F.
TR61	5V internal power supply failure	1. Check whether there is any short circuit abnormality in the 5V power supply; 2. Check whether the load is abnormal and whether there is a short circuit in the encoder or throttle circuit; 3. Replace the controller and perform motor self-learning again.
TR62	12V internal power supply failure	1. Restart the vehicle; 2. Replace the controller and perform motor self-learning again.
TR63	Motor temperature sensor error	1. Restart the vehicle; 2. Measure the resistance value of the motor's temperature sense, compare the resistance value of the temperature sensor with the temperature relationship table, and determine whether the temperature sense is abnormal; 3. Replace the motor and perform motor self-learning again.
TR64	Data storage error	1. Restart the vehicle; 2. Replace the controller and perform motor self-learning again.
TR65	Motor encoder data error	1. Restart the vehicle; 2. Replace the motor and perform motor self-learning again. 3. Replace the controller and perform motor self-learning again.
TR66	Controller internal communication error	1. Restart the vehicle; 2. Replace the controller and perform motor self-learning again.
TR67	Motor overtemperature warning	The motor temperature is too high. Wait for the motor to cool down, and then restart the power supply.
TR68	Controller overtemperature warning	The controller temperature is too high. Wait for the controller to cool down, and then restart the power supply.
TR69	Right parking brake manually disengaged and not reset	Reengage the right parking brake.
TR70	Pedal potentiometer error	1. Check the pin status of the potentiometer connector and whether the connector is connected properly; 2. Check whether the potentiometer voltage is within the range of 5V±0.5; 3. Detect the potentiometer voltage change range to see if there is any abnormal voltage jump; 4. Replace the potentiometer.

Error Codes	Errors Contents	Suggetions
TR71	Steering wheel potentiometer error	1. Check the pin status of the potentiometer connector and whether the connector is connected properly; 2. Check whether the potentiometer voltage is within the range of $5V \pm 0.5$; 3. Detect the potentiometer voltage change range to see if there is any abnormal voltage jump; 4. Replace the potentiometer.

13.2 LEFT WHEEL MOTOR CONTROLLER ERROR CODES

Error Codes	Error Contents	Suggestions
TL2	Drive motor stalled	1. Check whether the tires are stuck; 2. Check the pin status of the encoder connector corresponding to the motor and whether the connector is connected properly; 3. Check whether the phase wire of the corresponding motor is damaged and whether the phase wire installation is misaligned; 4. Check the parameter version and perform motor self-learning again. 5. Replace the motor and perform motor self-learning again; 6. Replace the controller and perform motor self-learning again.
TL4	Motor overspeed protection	1. Check whether the phase wire of the corresponding motor is damaged and whether the phase wire installation is misaligned; 2. Check the pin status of the encoder connector corresponding to the motor and whether the connector is connected properly; 3. Replace the motor encoder; 4. Perform motor self-learning again. 5. Replace the motor and perform motor self-learning again; 6. Replace the controller and perform motor self-learning again.
TL5	Motor encoder error	1. Check the pin status of the encoder connector corresponding to the motor and whether the connector is connected properly; 2. Replace the motor encoder and perform motor self-learning again; 3. Replace the controller and perform motor self-learning again;
TL6	Controller phase loss	1. Check whether the phase wire of the corresponding motor is damaged and whether the mounting screws are tight; 2. Replace the motor and perform motor self-learning again; 3. Replace the controller and perform motor self-learning again.
TL7	MOSFET error	Replace the controller and perform motor self-learning again.
TL8	Controller undervoltage	1. Replace the fully charged battery pack; 2. Replace the controller and perform motor self-learning again.
TL9	Controller overvoltage	1. Replace the battery pack with the same voltage platform; 2. Replace the controller and perform motor self-learning again.
TL12	Motor overtemperature	1. Check whether the tires are stuck; 2. The motor temperature is too high. Please wait for cooling before use and restart the power supply. 3. Replace the motor and perform motor self-learning again.
TL13	Controller overtemperature	1. Check whether the tires are stuck; 2. The controller temperature is too high. Please wait for cooling before use and restart the power supply. 3. Replace the controller and perform motor self-learning again.
TL14	Software Overcurrent	1. Check whether the phase wire of the corresponding motor is damaged and whether the mounting screws are tight; 2. Check the pin status of the encoder connector corresponding to the motor and whether the connector is connected properly; 3. Replace the controller and perform motor self-learning again; 4. Replace the motor and perform motor self-learning again.
TL15	Hardware Overcurrent	1. Check whether the phase wire of the corresponding motor is damaged and whether the mounting screws are tight; 2. Check the pin status of the encoder connector corresponding to the motor and whether

Error Codes	Error Contents	Suggestions
		the connector is connected properly; 3. Check the status of the MOS-FET of the controller; 4. Replace the controller and perform motor self-learning again ; 5. Replace the motor and perform motor self-learning again.
TL16	Potentiometer error	1.Check the pin status of the potentiometer connector and whether the connector is connected properly; 2. Check whether the potentiometer voltage is within the range of $5V \pm 0.5$; 3. Detect the potentiometer voltage change range to see if there is any abnormal voltage jump; 4. Replace the potentiometer.
TL19	Operating sequence error	1. Check whether the parking switch status changes normally; 2. Check whether the left potentiometer voltages exceed the dead zone range; 3. Check whether the seat switch status changes normally.
TL22	Electromagnetic valve error	1. Check whether the relay coil resistance is around 30Ω . If it is abnormal, the relay needs to be replaced; 2. Check whether there is a short circuit or open circuit in the wiring between the controller and the relay coil; 3. Replace the controller and perform motor self-learning again. 4. Replace the motor and perform motor self-learning again.
TL23	Battery compartment (PMU)communication error	1.Check the pin status of the PMU CAN connector whether the connector is connected properly; 2. Check whether PMU CANL and CANH are short circuited or open circuited; 3. Replace the controller and perform motor self-learning again.
TL26	CAN timeout error - right drive	1.Check the pin status of the CAN connector whether the connector is connected properly; 2. Check whether CANL and CANH are short circuited or open circuited; 3. Replace the controller and perform motor self-learning again.
TL30	Power off warning	Power has been shut down, please restart the vehicle.
TL31	Seat switch verification error	1.Check the pin status of the seat switch connector whether the connector is connected properly; 2. Check whether there is a short circuit or open circuit in the seat switch wiring; 3. Check whether water has entered the seat switch and whether the status of the switch changes normally ; 4. Replace the seat switch; 5. Replace the controller and perform motor self-learning again.
TL32	Software authentication error	1. Restart the vehicle; 2. Replace the traction controller and perform motor self-learning again.
TL60	Controller undertemperature	The temperature of the controller is too low. Please wait until the temperature rises to above -22.0°F and then restart the power supply.
TL61	5V internal power supply failure	1. Check whether there is any short circuit abnormality in the 5V power supply; 2. Check whether the load is abnormal and whether there is a short circuit in the encoder or potentiometer circuit; 3. Replace the controller and perform motor self-learning again.
TL62	12V internal power supply failure	1. Restart the vehicle ; 2. Replace the controller and perform motor self-learning again.

Error Codes	Error Contents	Suggestions
TL63	Motor temperature sensor error	1. Restart the vehicle ; 2. Measure the resistance value of the motor's temperature sense, compare the resistance value of the temperature sensor with the temperature relationship table, and determine whether the temperature sense is abnormal; 3. Replace the motor and perform motor self-learning again.
TL64	Data storage error	1. Restart the vehicle ; 2. Replace the controller and perform motor self-learning again.
TL65	Motor encoder data error	1. Restart the vehicle ; 2. Replace the motor and perform motor self-learning again. 3. Replace the controller and perform motor self-learning again.
TL66	Controller internal communication error	1. Restart the vehicle ; 2. Replace the controller and perform motor self-learning again.
TL67	Motor overtemperature warning	The motor temperature is too high. Wait for the motor to cool down, and then restart the power supply.
TL68	Controller overtemperature warning	The controller temperature is too high. Wait for the controller to cool down, and then restart the power supply.
TL69	Left parking brake manually disengaged and not reset	Reengage the right parking brake.
TL70	Pedal potentiometer error	1. Check the pin status of the potentiometer connector and whether the connector is connected properly; 2. Check whether the potentiometer voltage is within the range of $5V \pm 0.5$; 3. Detect the potentiometer voltage change range to see if there is any abnormal voltage jump; 4. Replace the potentiometer.
TL71	Steering wheel potentiometer error	1. Check the pin status of the potentiometer connector and whether the connector is connected properly; 2. Check whether the potentiometer voltage is within the range of $5V \pm 0.5$; 3. Detect the potentiometer voltage change range to see if there is any abnormal voltage jump; 4. Replace the potentiometer.

13.3 RIGHT BLADE MOTOR CONTROLLER ERROR CODES

Error Codes	Error Contents	Suggestions
MR 2	Blade motor stalled	1. Reset the PTO switch; 2. Check whether the blade are stuck; 3. Check whether the phase wire of the corresponding motor is damaged and whether the phase wire installation is misaligned; 4. Replace the controller; 5. Replace the motor.
MR3	Blade motor low speed	1. Reset the PTO switch; 2. Check whether the blade are stuck; 3. Check whether the phase wire of the corresponding motor is damaged and whether the phase wire installation is misaligned; 4. Replace the controller; 5. Replace the motor.
MR4	Blade motor over speed	1. Reset the PTO switch; 2. Check whether the blade are stuck; 3. Check whether the phase wire of the corresponding motor is damaged and whether the phase wire installation is misaligned; 4. Replace the controller; 5. Replace the motor.
MR6	Controller phase loss	1. Check whether the phase wire of the corresponding motor is damaged and whether the mounting screws are tight; 2. Replace the motor; 3. Replace the controller.
MR7	MOSFET error	1. Check the status of the MOS tube of the controller; 2. Check whether the phase wire of the corresponding motor is damaged and whether the mounting screws are tight; 3. Replace the controller.
MR8	Controller undervoltage	Replace the fully charged battery pack;
MR9	Controller overvoltage	1. Replace the battery pack with the same voltage platform; 2. Replace the controller.
MR13	Controller overtemperature	1. Check whether the blade are stuck; 2. The controller temperature is too high. Please wait for cooling before use and restart the power supply.
MR14	Software overcurrent	1. Reset the PTO switch. 2. Check whether the blade are stuck; 3. Check whether the phase wire of the corresponding motor is damaged and whether the mounting screws are tight; 4. Replace the controller.
MR15	Hardware overcurrent	1. Reset the PTO switch. 2. Check whether the blade are stuck; 3. Check whether the phase wire of the corresponding motor is damaged and whether the mounting screws are tight; 4. Replace the controller.
MR19	Operating sequence error	1. Check whether the cutter switch is pulled up; 2. Check whether the seat switch status changes normally.
MR25	CAN timeout error - left drive	1. Check the pin status of the CAN connector of the blade controller whether the connector is connected properly; 2. Check whether CANL and CANH of the blade controller are short circuited or open circuited; 3. Restart the controller.
MR26	CAN timeout error - right drive	1. Check the pin status of the CAN connector of the blade controller whether the connector is connected properly; 2. Check whether CANL and CANH

Error Codes	Error Contents	Suggestions
		of the blade controller are short circuited or open circuited; 3. Restart the controller.
MR27	CAN timeout error - left blade	1. Check the pin status of the CAN connector of the blade controller whether the connector is connected properly; 2. Check whether CANL and CANH of the blade controller are short circuited or open circuited; 3. Restart the controller.
MR28	CAN timeout error - middle blade	1. Check the pin status of the CAN connector of the blade controller whether the connector is connected properly; 2. Check whether CANL and CANH of the blade controller are short circuited or open circuited; 3. Restart the controller.
MR29	CAN timeout error - right blade	1. Check the pin status of the CAN connector of the blade controller whether the connector is connected properly; 2. Check whether CANL and CANH of the blade controller are short circuited or open circuited; 3. Restart the controller.
MR31	Blade switch verification error	1. Check the pin status of the PTO switch connector whether the connector is connected properly; 2. Check whether there is a short circuit or open circuit in the PTO switch wiring; 3. Check whether water has entered the PTO switch and whether the status of the switch changes normally ; 4. Replace the blade switch; 5. Replace the controller.
MR32	CAN timeout error - left blade	1. Restart the vehicle; 2. Replace the controller.

13.4 LEFT BLADE MOTOR CONTROLLER ERROR CODES

Error Codes	Error Contents	Suggestions
ML2	Blade motor stalled	1. Reset the PTO switch; 2. Check whether the blade are stuck; 3. Check whether the phase wire of the corresponding motor is damaged and whether the phase wire installation is misaligned; 4. Replace the controller; 5. Replace the motor.
ML3	Blade motor low speed	1. Reset the PTO switch; 2. Check whether the blade are stuck; 3. Check whether the phase wire of the corresponding motor is damaged and whether the phase wire installation is misaligned; 4. Replace the controller; 5. Replace the motor.
ML4	Blade motor over speed	1. Reset the PTO switch; 2. Check whether the blade are stuck; 3. Check whether the phase wire of the corresponding motor is damaged and whether the phase wire installation is misaligned; 4. Replace the controller; 5. Replace the motor.
ML6	Controller phase loss	1. Check whether the phase wire of the corresponding motor is damaged and whether the mounting screws are tight; 2. Replace the motor; 3. Replace the controller.
ML7	MOSFET error	1. Check the status of the MOSFET of the controller; 2. Check whether the phase wire of the corresponding motor is damaged and whether the mounting screws are tight; 3. Replace the controller.
ML8	Controller undervoltage	1. Replace the fully charged battery pack. 2. Replace the controller.
ML9	Controller overvoltage	1. Replace the battery pack with the same voltage platform; 2. Replace the controller.
ML13	Controller overtemperature	1. Check whether the blade are stuck; 2. The controller temperature is too high. Please wait for cooling before use and restart the power supply.
ML14	Software overcurrent	1. Reset the PTO switch. 2. Check whether the blade are stuck; 3. Check whether the phase wire of the corresponding motor is damaged and whether the mounting screws are tight; 4. Replace the controller.
ML15	Hardware overcurrent	1. Reset the PTO switch. 2. Check whether the blade are stuck; 3. Check whether the phase wire of the corresponding motor is damaged and whether the mounting screws are tight; 4. Replace the controller.
ML19	Operating sequence error	1. Check whether the cutter switch is pulled up; 2. Check whether the grass gathering switch is connected well. 3. Check whether the seat switch status changes normally.
ML25	CAN timeout error - left drive	1. Check the pin status of the CAN connector of the blade controller whether the connector is connected properly; 2. Check whether CANL and CANH of the blade controller are short circuited or open circuited; 3. Restart the controller.
ML26	CAN timeout error - right drive	1. Check the pin status of the CAN connector of the blade controller whether the connector is connected properly; 2. Check whether CANL and CANH

Error Codes	Error Contents	Suggestions
		of the blade controller are short circuited or open circuited; 3. Restart the controller.
ML27	CAN timeout error - left blade	1.Check the pin status of the CAN connector of the blade controller whether the connector is connected properly; 2. Check whether CANL and CANH of the blade controller are short circuited or open circuited; 3. Restart the controller.
ML28	CAN timeout error - middle blade	1.Check the pin status of the CAN connector of the blade controller whether the connector is connected properly; 2. Check whether CANL and CANH of the blade controller are short circuited or open circuited; 3. Restart the controller.
ML29	CAN timeout error - right blade	1.Check the pin status of the CAN connector of the blade controller whether the connector is connected properly; 2. Check whether CANL and CANH of the blade controller are short circuited or open circuited; 3. Restart the controller.
ML31	Blade switch verification error	1.Check the pin status of the PTO switch connector whether the connector is connected properly; 2. Check whether there is a short circuit or open circuit in the PTO switch wiring; 3. Check whether water has entered the PTO switch and whether the status of the switch changes normally ; 4. Replace the seat switch; 5. Replace the controller.
ML 32	Software authentication error	1. Restart the vehicle. 2.Replace the controller

13.5 POWER MANAGEMENT UNIT (IN THE BATTERY COMPARTMENT) ERROR CODES

Error Codes	Errors Contents	Suggestions
PMU2	Overtemperature-Level1	The vehicle is overloaded, please reduce the operating load or use it after cooling down.
PMU10	Open circuit in battery pack in PMU	Disconnected battery pack in battery compartment, product performance may be affected.
PMU11	PMU minor error	A minor error in the battery compartment prevented the blade system from starting. Wait for the system to recover, and then reset the blade start switch.
PMU12	PMU critical error	A major error in the battery compartment prevented the drive and blade systems from starting. Restart the power supply and try again.
PMU13	PMU no battery pack available	Check that you are using the correct battery pack, and then restart the power supply.
PMU35	Overtemperature-Level2	The vehicle is overloaded, wait for cooling down before use.
PMU36	Undervoltage	The voltage is too low. Charge the battery pack and try again.
PMU37	Overvoltage	The voltage is too high. Restart the power supply.
PMU38	Power supply output failure	1. Restart the vehicle; 2. Replace the battery pack and power on again.
PMU41	No battery pack available	1. Restart the vehicle; 2. Replace the battery pack and power on again.
PMU46	Relay (MOS) error	1. Restart the vehicle; 2. Insert individual battery packs into the battery compartment one after another and power them on to determine the abnormal channels. The idle corresponding abnormal channels can be used under limited conditions in emergencies; 3. The relay (MOS) of the battery pack channel is damaged, please replace the PMU.
PMU47	Pre-charge error	1. Check whether the B+ and B- output of the PMU are short-circuited; if short-circuited, you need to check the status of the MOS tubes of the controller one by one; 2. Remove or replace the battery pack with the highest voltage in the battery compartment and power on again; 3. PMU hardware failure, please replace the PMU.
PMU48	Pre-charge hardware error	1. Restart the vehicle; 2. PMU hardware failure, please replace the PMU.
PMU49	Negative MOSFET temperature sensor error	1. Restart the vehicle; 2. PMU hardware failure, please replace the PMU.
PMU52	Current sensor error	1. Restart the vehicle; 2. PMU hardware failure, please replace the PMU.
PMU57	KSI Pre-MOS error	1. Restart the vehicle; 2. PMU hardware failure, please replace the PMU.
PMU59	KSI MOS error	1. Restart the vehicle; 2. PMU hardware failure, please replace the PMU.

Error Codes	Errors Contents	Suggestions
PMU61	Battery pack 1 does not match	Replace the battery pack with the same voltage platform.
PMU62	Battery pack 2 does not match	Replace the battery pack with the same voltage platform.
PMU63	Battery pack 3 does not match	Replace the battery pack with the same voltage platform.
PMU64	Battery pack 4 does not match	Replace the battery pack with the same voltage platform.
PMU65	Battery pack 5 does not match	Replace the battery pack with the same voltage platform.
PMU66	Battery pack 6 does not match	Replace the battery pack with the same voltage platform.
PMU67	Abnormal charging status	1. Check whether the charger input plug is plugged in properly; 2. Check whether the switch status in the charging socket is abnormal; 3. Check whether the wiring harness from the charging socket switch to the PMU is open or short-circuited.

13.6 DISPLAY SCREEN ERROR CODES

Error Codes	Errors Contents	Suggestions
D1	CAN Timeout with PMU	1. Check whether the connectors of the display and PMU are connected properly; 2. Replace the display. 3. Replace the PMU.
D2	CAN Timeout with left traction controller	1. Check whether the connectors of the display and left traction controller are connected properly; 2. Replace the display. 3. Replace the PMU.
D3	CAN Timeout with right traction controller	1. Check whether the connectors of the display and right traction controller are connected properly; 2. Replace the display. 3. Replace the PMU.
D4	CAN Timeout with left blade controller	1. Check whether the connectors of the display and blade controller are connected properly; 2. Replace the display. 3. Replace the blade controller.
D5	CAN Timeout with middle blade controller	1. Check whether the connectors of the display and blade controller are connected properly; 2. Replace the display. 3. Replace the blade controller.
D6	CAN Timeout with right blade controller	1. Check whether the connectors of the display and blade controller are connected properly; 2. Replace the display. 3. Replace the blade controller.

greenworks[®]

www.greenworksaustralia.com



P0806612-00